

MUNK
SCHOOL
OF
GLOBAL
AFFAIRS



UNIVERSITY OF
TORONTO



MUNK SCHOOL BRIEFINGS

JULY 2010

The Importance of Steel Manufacturing to Canada – A Research Study

By
Peter Warrian, PhD
Senior Research Fellow
Munk School of Global Affairs
University of Toronto

MUNK SCHOOL BRIEFINGS

The Importance of Steel Manufacturing to Canada – A Research Study

By

Peter Warrian, PhD

Senior Research Fellow

Munk School of Global Affairs

University of Toronto



MUNK SCHOOL OF GLOBAL AFFAIRS
UNIVERSITY OF TORONTO

Munk School of Global Affairs
At Trinity College
University of Toronto
1 Devonshire Place
Toronto, Ontario, Canada M5S 3K7
Telephone: (416) 946-8900
Facsimile: (416) 946-8915
E-mail: munkschool@utoronto.ca
Website: www.munkschool.utoronto.ca

© Peter Warrian

978-0-7727-0845-8
ISSN 1715-3484

The University of Toronto's Munk School of Global Affairs is a hub for specialists in global affairs, providing innovative approaches to the challenges, organizations, and ideas that are at the frontiers of knowledge. Today, to become global leaders, students need not only the core functional disciplines, but also a deep understanding of the broader architecture and the forces that shape the global system. Against the backdrop of one of the world's most diverse cities, the Munk School is convening a vital dialogue about the forces that are reshaping the international landscape – creating an environment which will equip students to thrive in a world where working internationally demands not only professional skills but strategic agility and cultural fluency.

MUNK SCHOOL BRIEFINGS

1. *Bound to Follow? US Foreign Policy, International Reactions, and the New Complexities of Sovereignty*. By Louis W. Pauly.
September 2005 ISBN 0-7727-0825-5.
 2. *The Multilateral Agenda: Moving Trade Negotiations Forward*. By Sylvia Ostry.
November 2005 ISBN 0-7727-0822-3.
 3. *The Jerusalem Old City Initiative Discussion Document: New Directions for Liberation and Dialogue*. By Michael Bell, Michael J. Molloy, John Bell and Marketa Evans.
December 2005 ISBN 07727-0823-1.
 4. *Comparative Program on Health and Society Lupina Foundation Working Papers Series 2004–2005*. Edited by Jillian Clare Cohen and Jennifer E. Keelan.
January 2006 ISBN 0-7727-0818-5.
 5. *Comparative Program on Health and Society Lupina Foundation Working Papers Series 2005-2006*. Edited by Jillian Clare Cohen and Lisa Forman.
October 2006 ISBN 0-7727-0829-0.
 6. *Darfur and Afghanistan: Canada's Choices in Deploying Military Forces*.
By Ambassador David S. Wright.
October 2006 ISBN 0-7727-0830-4.
 7. *Trade Advocacy Groups and Multilateral Trade Policy-Making of African States*.
By Sylvia Ostry and Thomas Kwasi Tieku.
April 2007 ISBN 978-0-7727-0832-8.
 8. *Water Diversion, Export, and Canada-U.S. Relations: A Brief History*.
By Frank Quinn.
August 2007 ISBN 978-0-7727-8054-6.
 9. *Intersubjectivity in Literary Narrative*. By Tomas Kubicek
October 2007 ISBN 978-0-7727-0834-2.
 10. *Comparative Program on Health and Society Lupina Foundation Working Papers Series 2006-2007*. Edited by Jillian Clare Cohen-Kohler and M. Bianca Seaton.
November 2007 ISBN 978-0-7727-0838-0.
 11. *A Model Act for Preserving Canada's Waters*. Canadian Water Issues Council in collaboration with the Program On Water Issues.
February 2008 ISBN 978-0-7727-0839-7.
Loi type sur la protection de l'eau au Canada. Conseil sur les questions de l'eau au Canada en collaboration avec le Programme sur les questions de l'eau.
Février 2008 ISBN 978-0-7727-0840-3.
-

MUNK SCHOOL BRIEFINGS (CONTINUED)

12. *The World's First Anti-Americans: Canada as the Canary in the Global Mine.*
By Richard Gwyn.
March 2008 ISBN 978-0-7727-0842-7.
13. *Comparative Program on Health and Society Lupina Foundation Working Papers Series 2007-2009.* Edited by M. Bianca Seaton and Sara Allin.
April 2010 ISBN 978-0-7727-0844-1.
14. *The Importance of Steel Manufacturing to Canada – A Research Study.*
By Peter Warrian.
July 2010 ISBN 978-0-7727-0845-8.

Disclaimer

This paper is an independent research report conducted at the Munk School of Global Affairs, University of Toronto. While this research was sponsored by the Canadian Steel Producers Association, the Canadian Steel Trade and Employment Congress and the United Steelworkers, the findings and opinions expressed in this report are those solely of the author, and do not necessarily represent the views or positions of the sponsoring organizations nor any of their members.

To the Reader

April 25, 2010

To the Reader

The fundamental purpose of this study is to analyze the value, importance and benefits of the steel industry to the Canadian economy and its contribution to our society.

Specifically, the analysis examines the impact of the following factors:

1. The domestic basic steel-producing industry, including pipe and tube production, and its role in major industrial clusters within the broader Canadian manufacturing sector;
2. Steel's relative economic contribution in terms of productivity, multipliers, value-added economic activity, and direct and indirect employment;
3. Canadian steel value-chains, both backwards (raw materials e.g. iron ore, coal, scrap) and forwards (end-use applications, distribution networks), including associated value-added service industry impacts, e.g. logistics, engineering;
4. The Canadian steel market in a North American and global context, including the competitive risks and opportunities;
5. The range and variety of global competitive forces at work, including the role of public policy in other jurisdictions, which impact steel production in Canada;
6. The potential economic consequences of a loss of or reduction in Canadian steel producing capacity.

The analysis incorporates the concept of industrial clusters to underscore the importance of a domestic steel industry to other industrial activities.

Three sources of data are used in the study:

- a) Macro-economic data, including a review of relevant input-output simulations of the financial and employment impact of steel on the Canadian economy.
- b) Micro-economic data obtained from steel companies concerning the payroll, taxes, goods and services procurement and community support activities in local and regional economies.
- c) Case studies and stories of steel companies interacting in partnership with customers, suppliers and public institutions to reflect the broader contribution of the steel industry to the Canadian economy and communities.

Field research was also conducted as part of this study.

Interviews were conducted with over 40 senior managers and executives in steel companies, and an approximately equal number in Customers and Suppliers, plus union representatives of the United Steel Workers at the local and national levels.

Sincerely,

Peter Warrian PhD, DSL
Senior Research Fellow
Munk School of Global Affairs
University of Toronto

TABLE OF CONTENTS

DISCLAIMER	vi
TO THE READER	vii
TABLE OF CONTENTS	ix
EXECUTIVE SUMMARY	xi
1. INTRODUCTION:	1
The Perspective of this Report	1
1.1 The Steel Industry	2
Steel Industry Basics	2
The Classic Steel Industry	2
NAFTA & Regional Steel	3
Steel and Regions	3
The Steel Mill(s)	4
Learning from Steel	4
Manufacturing in the New Economy	5
Steel Success and Public Policy	6
High Tech Steel	6
Steel, People and Talent	7
2. THE IMPACT AND CONTRIBUTION OF STEEL TO THE CANADIAN ECONOMY	8
2.1 Steel Industry Multiplier: Macro-economic Simulation Results	9
2.2 Regional and Local Impacts: Micro-economic Data	10
2.3 Death Star Scenario: What If No Steel?	12
3. STEEL: THE ANCHOR OF INDUSTRIAL CANADA	13
3.1 Steel in Canadian Economic History	14
3.2 Steel Manufacturing as Canada's Industrial Anchor	15
3.3 The Postwar Steel Industry	19
Role of Public Policy in Steel Industry Development	20
The Role of Tariff Policy	22
3.4 C.D. Howe's Steel Industry	23
Vision of an Integrated Steel Industry	23
Postwar Steel Innovation: BOF, CCM	24
4. CANADIAN STEEL IN A GLOBALIZED INDUSTRY	25
4.1 Access to Capital and Technology	27
4.2 Restructuring of World Steel: China vs Brazil	33
4.3 New Technology and Talent Flows	35
5. THE STEEL CLUSTER	36
5.1 Natural Steel Manufacturing Cluster	36

5.2 Steel Technology Cluster	38
5.3 Cluster Economic Rents	46
5.4 Working with Customers and Suppliers	47
Steel Companies Partnering with Their Customers	47
Working With Suppliers	53
6. STEEL IN THE KNOWLEDGE ECONOMY	54
6.1 The Japanese Steel Revolution	54
6.2 Knowledge and Skills on the Shop Floor	56
6.3 The Steel Mill as Laboratory	57
6.4 How Steel Companies Learn	58
4.5 Steel Knowledge Networks	60
7. THE STEEL GROWTH STORY	63
7.1 NAFTA Steel Market	64
7.2 Auto Steels	67
7.3 Energy: Alternative and Conventional	68
7.4 Construction: The Big Surprise ?	70
Materials Competition in Auto and Construction	72
8. STEEL TRADE ISSUES	73
8.1 Global Economic Crisis	73
8.2 Impact of China	74
8.3 Key Trade Flow Drivers	79
8.4 Steel Trade Disputes	79
8.5 Trade Liberalization	82
9. STEEL, THE ENVIRONMENT AND RECYCLING	83
9.1 Steel Recycling Story	85
9.2 Steel Scrap	86
9.3 Energy: Counter-Intuitive and Ontario Power Authority (OPA)	88
10. A SUSTAINABLE STEEL INDUSTRY FOR THE FUTURE	89
10.1 Conventional Policy Issues	89
10.2 New Policy Issues	90
10.3 A Horizon of Supportive Public Policy	91
10.4 Policies for Steel	92
APPENDIX 1: A SHORT HISTORY OF CANADIAN STEEL	96
A Short History of Canadian Steel	96
The National Policy Steel Industry	96
C.D. Howe's Steel Industry	100
The Tipping Point Between Stelco and Dofasco	102
Historical Bibliography	109
APPENDIX 2 – METHODOLOGY	110
REFERENCES	111

Executive Summary

The steel industry is important to Canada because:

It employs directly and indirectly 130,000 Canadian men and women across Canada.

It produces a versatile material that is essential to many other key industries, our life style, our transportation and our physical infrastructure.

It will play a key role in our energy and environmental future, including the products and technologies of a “greener” economy.

It produces \$7 billion per year in exports.

It is a critical element in a sustainable manufacturing sector for the Canadian economy of the future.

From an employment, value-added, knowledge intensive and environmental perspective, this is an industry Canadians should want in their future.

The role of the North American steel industry is not, as some might contend, over. It is far from inevitable that steel production will simply shift to China. The North American steel industry is and can remain competitive, and has great potential to contribute further to the kind of economy and society that all Canadians want for the future.

We are using more steel in the economy, not less, over time. But it's different steel and we will continue to need better steels and new kinds of steel in future.

Steel Sustainable Manufacturing. It is the most recycled material. Canada's steel industry has more than matched Kyoto targets on reductions in greenhouse gases (GHGs), principally carbon dioxide (CO₂).

Conventional energy sources like oil and gas require steel-based products for extraction and processing, and are distributed through steel pipe and tubular products. Steel is necessary to electricity generation and distribution.

Alternative energy sources like wind and solar use steel towers and frames.

Steel is the most recycled product in the world, and steel scrap can be endlessly re-used. Using scrap reduces CO emissions and removes metals from our physical environment.

A zero discharge steel mill is theoretically possible but will take breakthrough technologies that will take many years to develop and apply.

Steel mills can be co-producers of energy as well as producing steel products.

The steel industry in the 20th century was a leading example of Canadian industrial success. It was the largest and most successful Canadian owned and managed industry and set of companies in the country. If we didn't have the steel industry we have, we wouldn't have the industry or society that we have today.

Steel's direct employment contribution to the economy is only part of the story. It has to be taken in the context of steel's other contributions to the economic capabilities in manufacturing, energy and construction, as well as the other 'steel cluster' linkages. Steel mills also have important local community impacts.

Canada's modern steel industry is over 100 years old this year, beginning with the consolidation of the Steel Company of Canada in 1910. Between the two World

Wars, the mass consumer society of automobiles, appliances and skyscrapers were built with steel. WWII saw government policy significantly shape a fully integrated steel industry. It is not an exaggeration to call the postwar steel industry C. D. Howe's Steel Industry.

In 1957, government intervention in the form of the tariff system that had facilitated the industry's early growth was basically ended in the context of the postwar GATT system.

The first 75 years of the steel industry in Canada was largely the story of the emergence and leadership of Stelco. In the next 20-25 years, it became the surpassing of Stelco by Dofasco which developed a new sort of 'learning' steel company. Several other steel producers, and the advent of "minimills" as a new way to make steel, further developed the industry in Canada.

Many people view the steel industry as the antithesis of the new knowledge-based economy. The reality is that the knowledge and information-based economy are alive and well in steel, and have been for a long time. The information economy was emerging in steel mills during the 1960s and 1970s, twenty years before it became a common term in economic discourse. And steel itself is an advanced industrial material, engineered to a wide variety of product characteristics and applications.

That was all then and this is now. We have now entered a different era of Canadian steel in a globalized industry, with significant transformation around the world. Indigenous technical development within individual steel companies has now become much less important than technology transfer, licensing and industry consortia. New steel knowledge networks have surpassed individual company labs. Innovations are sometimes driven by steel producers and sometimes the steel companies are pulled by their customers. Other times, it comes from outside third-party sources.

For steel producers there is a natural steel 'cluster' of steel companies and their manufacturing customers that have to locate close by because the product itself – steel coils, bars, beams, and pipes – is heavy and therefore has high transportation costs. The freight cost variable is one fundamental determinant of cluster behaviour in steel. The other is the close affinity and internal linkages of steel and industrial clusters to which it is central. The lesson is that the steel mill is a hub. It goes to the heart of changes in advanced manufacturing in general. A primary example is the model of the auto industry supply chain, the lead customer for steel and the reference point for modern lean production. But the same applies to other applications and industrial clusters.

There is also a Steel Technology Cluster. It is comprised of the steel producers and their suppliers of material and professional services, engineering, logistics, etc. It comprises 106 firms across the country, largely but not exclusively located in Ontario and Quebec. There is an additional cluster in Western Canada driven by and built around the energy and other resource sectors in the region.

The steel industry has become globalized in an unprecedented way during the first decade of the new century. While the loss of domestic ownership and local control are undeniable consequences, it is important to recognize that this is not only a Canadian phenomenon and the industry and its capabilities did not disappear. The change of ownership has been accompanied by several benefits including access to managerial talent, technology and capital pools.

The most immediate, practical impact of this ownership transformation has been significant cost savings through global benchmarking of best practices within the new global steel management. It also offers access to investment capital that was beyond the ability of independent ownership. However this improved and expanded access to capital and technology comes at a price. Canadian operations are in intense competition with sister facilities in other countries trying to get their investment projects accepted and funded by the same head offices. For this reason, there is an even greater necessity to frame public policies that best support future investment in the Canadian industry. Ideally, there should be a natural, supportive alliance between local steel management teams and Canadian policy makers.

Steel has a growth story.

Some observers are concerned the industry will be flat or decline in the coming decades. In considerable measure, this is based on one's view of the auto industry and whether auto leads a downtrend in manufacturing as a whole. Two factors might bend a flat/declining line for auto steel demand in a more optimistic direction. First there is room for the development of non-auto applications of modern auto steels into other areas of manufacturing. This could mean an increase of 5% in steel demand. The second factor may be new uses of steel products in construction. The market for flat-rolled steel could be at a tipping point and result in 20% growth over time, equal to auto.

Beyond automotive steels, there are many other forces that will build demand for steel, and thus the potential for Canadian steel mills. To begin, as the BRIC and other developing countries continue their long-term economic development, the world will require much more steel. Within established North American markets, demand growth for conventional uses will expand for several reasons. The recovery from the "Great Recession" will see demand increase. The need to invest in new and upgraded physical infrastructure (e.g. bridges, highways, municipal utilities, electricity grids) requires steel. Conventional energy developments will continue to demand steel products, and manufacturing and steel executives talk effusively about the potential for steel to contribute to alternate energy developments, from wind to solar power.

Overshadowing all global perspectives on steel is the China Steel Story. The stunning story of the emergence of China as by far the leading global steel producer is now recognized by all. At present, China accounts for about 40% of total global steel capacity and perhaps as much as 50% of operating capacity. This is despite the reality that China has relatively few resources that give it national advantage for steelmaking. It is heavily reliant on imported inputs such as iron ore, coal and scrap.

For Canada, as well as many other countries, China's policies and intentions in steel are critical for what we may expect in the future for our steel industry. China will not nor should it produce all the steel for the world. It is not possible physically or economically, nor desirable environmentally, and China itself does not have that goal. The rebalancing loops for global steel will be led by other states and markets, combined with continued focus on China's steel trade policies

Technical experts in steel believe that over the next decade the determinative variable in future technology trends within the steel industry will be driven by environmental and energy policies. Ironically, steel has more than met the much disputed Kyoto GHG standards over the past decade. Reductions of 1% or more per year in emissions have

been and continue to be achieved. Nonetheless, an even stronger focal point for the next decade will be environmental policy and regulation. At the core of the issue is the basic steel producing furnace technology. The huge improvements of the last decades cannot be replicated due to the limits of current technologies. New steelmaking technologies to develop major new breakthroughs are in the research and development stage globally, with several options being pursued.

In addition to GHGs, the industry has made enormous strides in reducing its particulates and effluent discharges during the last twenty years. All steel mills, for instance, try to minimize discharges and recycle their water.

Recovered and scrapped steel can be endlessly recycled into construction and other applications. Steel mills work with scrap dealers to pull product from municipal dump sites. Steel's magnetic properties make this quite efficient compared to other materials. The EU has the most complete recycling programme and rules. The life cycle perspective should be a guide for future policy across the materials and manufacturing sector.

It is one of the goals of this Report to examine the changes and opportunities of the Canadian steel industry and indicate directions in which public policy may support and assist it in taking advantage of future opportunities.

The Federal government has clear, traditional roles in international trade and commerce, taxation, transportation, and some areas of environmental regulation.. At the same time, the new opportunities in alternate energy applications of steel and the critical opportunities in construction very much correlate with provincial jurisdictions, e.g. building Codes and trades' training and certification, and much of the energy-generation sectors, e.g. provincial power utilities. Both levels of government play important roles in the critical area of innovation – helping to develop a skilled workforce on the one hand, and new technologies on the other, that will be required by Canadian manufacturers including steel producers.

Sections of this Report inevitably talk about the economic and business history of the industry. Its relevance is to describe briefly how we got to where we are - what changed in the last decade and especially the past five years from two core drivers: global consolidation and China's rapid and aggressive entry into the global steel market. It also suggests what these changes imply for the future, i.e. benefits of consolidation, but also opportunities and risks for Canadian producers from future investment to capacity shutdowns.

Steel in the future will be a central part of the materials infrastructure of our sustainable economy and society. Our design and production of the materials we need is only limited by our imagination and dialogue about the environment, life style and economy we want for ourselves and our children. The materials will be there to match the vision.

The impact on the economy in the future by the Canadian steel industry will not be determined by econometric input/output tables. The steel industry will have a future to the extent that it is able to be a continual, active partner with other social and economic groups about what kind of economy and society we all want in the future.

The Importance of Steel Manufacturing to Canada – A Research Study

Peter Warrian, PhD

1. Introduction: The Perspective of this Report

Steel industry people carry around a lot of history. This is no surprise because the industry is one of the established foundation stones of the economy, and industry participants can look at a long list of economic, technical and commercial contributions to the Canadian economy and indeed to Canadian society. It may not be as obvious in downtown Toronto, Montreal or Vancouver, but there is no debate about it in Hamilton, Sault Ste. Marie, Contrecoeur or Regina. Among other things a standard employment multiplier used in economic analysis points to the fact that there are many more jobs outside the industry for every direct job in steel. In addition, while most people understand and appreciate the importance of the auto industry to the steel industry – its biggest single consumer – what needs to be equally appreciated is the contribution of steel to other sections of manufacturing and our vital infrastructure. If we didn't have the steel industry we have, we wouldn't have the range of other important industries or the society that we have.

While history is important, this Report is not about building a testimonial nor placing a lot of black crepe paper around the country's steel mills. It is about the future. Understanding the past and present of the steel industry is fundamental to understanding its future, and the future of the economy as a whole. We hear a lot about the growth of the service sector and the declining importance of manufacturing. However, a large number of those services - and the way the statistics are tabulated understates it - are directed to supporting manufacturing activity directly and indirectly (e.g. business services, distribution, customer service etc.). Further, the steel industry accounts for

billions of dollars in exports each year. Our standard of living depends on our ability to compete globally. Goods production still accounts for the overwhelming proportion of our exports and it is the traded sector that ultimately determines the level of the domestic standard of living. As we famously see in the Wal-Mart case, you might have a reasonably full employment service sector economy but not at an income level you would want to have. Further, without generating jobs and growth in traded sectors, there won't be the customers for the service industries. And from a societal point of view, the tax base to sustain important government services will diminish.

These are some of the reasons readers should be interested in learning about the steel industry. It is important to learn about the steel industry in its own right and for what it can teach us about the economy as a whole and its future.

1.1 The Steel Industry

Steel Industry Basics

For most people, the steel industry is an outdated image and a distant object. This Report tries to make it accessible and understandable. The following is a profile of the industry and its changing role in the economy.

The Classic Steel Industry

For most of the 20th century the key steelmaking process was the Open Hearth Furnace. This was the classic steel industry portrayed in art, literature and the movies with streams of sparks and molten metal showering teams of workmen in huge, dark cavernous buildings with earth floors. It fully came of age in the 1920s with the emergence of the consumer economy of cars, refrigerators and other appliances. The material of choice for the manufacture of consumer durables was steel. It was a different kind of steel and steel processing than previously used for nails and bolts, steel plate for ships or steel rails for transportation. This is particularly relevant in Canada where rails were the bedrock of the National Dream.

The new Consumer Economy required sheet or flat-rolled steel as the basic input for manufacturing. Hot strip mills as they were called were the key technology but for a time this created a bottleneck. Traditionally sheet steel was rolled by teams of steelworkers physically passing sheets back and forth through a rolling machine until it

reached its proper dimensions. This process was expensive, highly labour-intensive, and time consuming. The more efficient continuous hot strip mill was developed in Butler, Pennsylvania in 1926 which opened the way to produce the huge volumes of flat rolled products to feed the burgeoning consumer durables market. This sort of steelmaking took off in Canada during the Postwar consumer boom with the introduction of Stelco's first hot strip mill in 1946. This marked the emergence of the modern consumer-oriented steel industry in Canada.

NAFTA & Regional Steel

Changing market and organizational structures are defining Canada's Next Steel Industry. We now have a NAFTA steel industry though not fully so. There are still restrictions around infrastructure and military markets because of Buy American and other provisions. The industry fought long and hard for more open access to the US market and greater openness was finally achieved in the early 2000s. However, beginning around the same time, the industry in Canada and the US would experience a new wave of global steel restructuring. New, huge international steel conglomerates began to acquire and merge steel production facilities across the three key steel markets in the world: Europe, North America and Asia. This unprecedented globalization and restructuring provided the context for the recent takeovers of Canadian independent steel producers Dofasco, Stelco, Algoma and Ipsco by global steel companies.

Steel and Regions

While we speak of a national steel industry, most modern steel production in advanced countries is decentralized into regional markets responding to market and cost factors, especially transportation.

Basic Oxygen Furnaces (BOF) producers have focused on specific product markets. The Ontario steel industry became predominantly a player in the auto industry, while the Western steel industry is most oriented to the needs of the oil and gas and other resource industries. Meanwhile, the smaller scale Electric Arc Furnaces (EAF) producers were emerging away from centralized steel areas around Pittsburgh and Hamilton, both to be closer to scrap steel sources and to gain advantage in local and regional markets for products such as rebar (construction), steel wire (multiple forms), buildings, and myriad

other industrial uses. Today, steel producers mostly locate and produce for regional markets, particularly in their finishing capacities. This trend has been reinforced by Canada's regionalized economy.

As a result, relevant public policy now includes not only federal issues like tax, trade and the environment, but also the provincial and even local levels of government.

Trade issues such as tariffs, dumping and subsidies are still important concerns for the steel industry. These remain important. However the future success of steel companies and the industrial clusters they generate, increasingly depend on local and regional networks of innovation and infrastructure encompassing steel producers, their customers, and their suppliers.

The Steel Mill(s)

Steel producing facilities are divided into two categories according to their technologies of steel production. Throughout this Report reference will be made to 'integrated steel mills' and 'minimills.'

Integrated steel mills use the traditional technology of making "virgin" steel from raw material inputs of iron ore, coal, limestone, etc. in Blast Furnaces (BF). Sometimes these are also called by the associated process Basic Oxygen Furnaces (BOF) Producers. There are certain advanced steels that can only be produced through this process, although a certain amount of recycled steel scrap is part of the recipe.

The second steel producing technology uses Electric Arc furnaces (EAFs) employing very powerful electrical charges to melt recycled steel from scrap sources. EAFs now account for about half of North American steel production. Some companies such as traditional integrated producers like Dofasco and Algoma use both technologies. BOF furnaces are larger than EAFs, but the latter can be more easily scaled up and down as demand for product shifts. Both play an essential role in the Canadian steel industry.

On the human resources side, all North American integrated producers except Arcelor Mittal-Dofasco are unionized. In Canada the minimills are all unionized; in the US many EAF producers are non-union.

Learning from Steel

Many observers are quick to say that the steel industry has

disappeared, or soon will so, and all steel production, indeed much of global manufacturing, will inevitably gravitate to China. As we shall see neither statement is true.

The steel industry example raises several key questions and lessons concerning its own future, but also about the future of the Canadian manufacturing industry as a whole. Indeed, it reveals issues and dynamics of industrial development across so-called post-industrial economies.

First, what is the place of manufacturing in the new, information-based economy?

Second, what is the future for Canadian industrial capabilities? A generation ago, Canadian managers and Canadians as a whole were concerned about foreign ownership (largely American) and its potential takeover of the Canadian economy. Now the greater fear is the prospect of being wiped out altogether by the rising industrial juggernaut of China.

Third, industrial management and industrial policies, whatever their merits and demerits, can easily be overwhelmed by trade trends and shifts in trade policies.

Manufacturing in the New Economy

This Report argues that manufacturing, in this case steel manufacturing, has a bright future. However it faces great challenges in realizing the potential. Two critical factors will particularly determine the viability of that future path.

In ten years, we will not be making the classic distinction we conventionally make between goods production and services in the economy. Industrial production will only be viable if it satisfies human needs and does not excessively impair the physical environment. We are all familiar with the exhortation for our industries to become more innovative in order to boost productivity, become more competitive and sustain a high wage economy. A continuing focus on innovation and improved productivity, and a highly-skilled workforce, is essential. All this is true.

It also means that manufacturing companies will increasingly resemble service companies instead of classic industrial commodity producers. As Dofasco used to say, they don't sell steel, they sell solutions. Understanding, leveraging and taking advantage of the

information content and design potential in the steel – its basis in advanced metallurgy – will be key to how the steel industry manages its future. The critical success factor will be its fundamental capacities to innovate and its skills and human resource capabilities. Therefore examination of innovation in the steel industry is a key theme in this Report.

Steel Success and Public Policy

The Royal Commission on Canada's Economic Prospects in 1956 (Gordon Commission) rated the steel industry at the top of its charts and tables for Canadian ownership and entrepreneurship. It was Canadian owned, internationally competitive and placed well in global productivity comparisons. In the early 1980s, Canada was second only to the Japanese and well ahead of the Americans and Europeans in international productivity comparisons. It has to be noted that this success was achieved with major highly supportive from Canadian tax, commercial and trade policy.

However, the last twenty years presented many challenges to the industry. Trade disputes with the US have erupted repeatedly, to Canada's disadvantage. Much investment in new productive capacity in the 1980s and 1990s was diverted by Canadian steel companies building new facilities in the United States. The industry voted with its feet in the face of intractable steel trade disputes.

Steel along with agriculture were the two industries most frequently afflicted by trade disputes in the Post-war global trading system of the GATT. The negotiation of the FTA in 1989 and subsequently the NAFTA was a response, among other things, to the steel trade wars between the US and Canada in the 1970s and 1980s. US protectionism drove to distraction Canadian steel producers, who had an inherent productivity and cost advantage over their US competitors in the shared North American market. The industry in the 1980s and 1990s desperately wanted and needed guaranteed access to the US market. They didn't get it. It would only come, albeit not completely, after a long process and was only realized in the context of the global players entering Canada and the US.

High Tech Steel

Technical innovation has always been important in steel, as in all capital intensive industries. However it has taken on heightened importance in the last decade while changing its character and focus.

The emergence of the modern industrial corporation was closely linked to the development of the industrial laboratory based on the German model of the industrial corporation in the late 19th century. The pioneers were German companies like Siemens followed in the early part of the 20th century by American corporations like DuPont. By mid-century, all major industrial corporations had developed large, specialized laboratories for product development.

In the steel industry, the leader in that day was US Steel which once employed as many research scientists and engineers as all the rest of the steel companies combined. Similarly, in Canada, Stelco had its Stelco Engineering division and was the undeniable technical leader for the whole Canadian steel industry in the postwar period.

In the 1990s, the world of steel innovation changed. The major companies cut back or cut out their research and development facilities. They believed they were fighting for their very existence and could not afford such luxuries. They believed that they could always license the latest technology from the global leaders.

Deep metallurgical engineering, technical research and development became the specialty of a limited number of global players like Nippon Steel and NKK in Japan and Usinor in Europe, while other producers increasingly depended on technology transfer and licensing i.e. traded knowledge. Dofasco for example, depended heavily on NKK in Japan for steelmaking technology and Usinor for automotive applications.

The second stream was commercial application development in which steel companies analogized to software companies. They would develop specialized, local applications based on underlying languages (metallurgical technologies) that they licensed from others. This included the fundamental alliance between Dofasco and Arcelor for new applications which helped to account for Dofasco's success in passing Stelco as the Canadian industry leader in the 1990s.

Steel, People and Talent

As mentioned above, the steel industry has been one of the icons of the mass production industrial age. Huge facilities and huge investments in capital equipment have been characteristics of the business and at times the bane of its existence. Skills within steel companies were basically organized around a tight hierarchy of engineering/management at the top. Very few CEOs of steel companies in the 20th century did not come from the engineering

staff. And, beneath this hierarchy there was a mass of unskilled and semi-skilled industrial workers and labourers.

Frederick Taylor, who wrote the famous *Principles of Scientific Management* in 1911, did his original work in the steel industry and developed the industrial model that sought the unending breakdown of jobs into simpler, less skilled components. The steel industry took this philosophy to heart and tried to implement it more systematically than any other major industry. The eventual codification of the whole system of jobs in the steel industry - the Co-Operative Wages Study (CWS) system - in the era of unionization gives skills in steel a uniquely hierarchical and fragmented character that still besets the industry today.

Skills and talent are vital to the future of the steel industry; in fact these two factors will largely determine its future success or lack of success. Internally within steel mills, skills and work organization require a fundamental shift in both union and management attitudes. Externally, the industry can learn from the Dofasco model of externally oriented innovation, leveraging the interface with its customers rather than exclusively relying on indigenous technical development within the corporation. Its anchor will ultimately be in the metallurgy but its commercial success will be in the socio-technical capacities of its work teams. There will also be new opportunities to partner with universities, colleges and public laboratories like the new CANMET labs in Hamilton to push forward with new developments.

The context for these developments will be the ability of steel companies to work within the new international steel innovation networks. In the literature on innovation, people talk about the differing 'absorptive capacity' of organizations. Many steel companies participate in the same international steel meetings and receive the same generic technical information, however some simply learn more and implement faster.

2. The Impact and Contribution of Steel to the Canadian Economy

What is the impact of the steel industry on the Canadian economy? The simplest answer is that directly and indirectly it accounts for about 130,000 jobs.

One must begin by defining the Steel Industry in statistical and

categorical terms. Unfortunately there is not one single simple statistical definition of the Canadian steel industry. (For details see the Methodological Appendix.)

After arriving at a definition comes measurement and then estimation.

The traditional way of measuring the economic impact of industries is to estimate the employment Multiplier. This is a Keynesian measure of the impact on employment of an additional unit of economic demand for the sector's goods. In practical terms, it seeks to estimate the additional jobs outside the industry for every job created within steel.

2.1 Steel Industry Multiplier: Macro-economic Simulation Results

In 2007, Informetrica of Ottawa did a study of the multiplier for Canadian manufacturing industries, including steel. It utilized a standard national-level input/output model and estimated the impact on a matrix of industries for an additional \$10 billion in exports over three years. The model was not a perfect fit for steel however, because the Primary Metals and Fabricated Metals industrial group includes not only virtually all of the firms in the steel industry, but also includes things like aluminum. Despite this limitation, it is a reasonable proxy.

On the basis of the Informetrica model, the steel industry has a multiplier of approximately 3.3:1; that is, there are 3.3 jobs outside of the steel industry for every direct job within the industry. More specifically, there is one additional manufacturing job and 2.3 additional service sector jobs, private and public sector combined.

This is a significant number but other approaches suggest that the multiplier may be larger.

In the auto industry, a recent projection for the Ontario Manufacturing Council by Spatial Economics has estimated a multiplier of seven or more. In part this is the result of a different modeling approach. The Informetrica Model is a top down model. The Spatial Economics model uses a bottom up approach. There are also important differences between the auto and steel industries. The long supply chains of the auto industry, particularly the auto parts sector, inherently give it a larger footprint upstream. Steel, by contrast, imports significant amounts of iron ore, coal, scrap and even slabs, so it will have a smaller impact than auto.

Extrapolating from these two studies suggests that the steel Multiplier number will be somewhere between 3.5 and 7.0.

The logic of this analysis concludes that steel supports approximately 130,000 jobs across the economy. This is a significant figure but is still less than 1% of Canada's workforce. These are also high wage jobs, with above average productivity and contribute significantly to export earnings for the country.

This estimate of Steel's employment contribution to the economy has to be taken in the context of Steel's other contributions to the economic capabilities in manufacturing, energy and construction as well as the other 'Steel cluster' linkages discussed elsewhere in this Report.

In addition to the direct multiplier, descriptions and data about Steel's linkages to other Canadian industries, investment, innovation, environmental benefits and quality of jobs are just as important to understanding its value as an industry that goes well beyond its measurable absolute jobs impact.

2.2 Regional and Local Impacts: Micro-economic Data

At an immediate, practical level, the economic impacts of the steel industry are primarily on regional and local economies. That is where the story is best understood. To this end, the Canadian Steel Producers Association (CSPA) compiled data from its members on the individual steel facilities contributions' to local economies including:

- Local sourcing of materials and professional services
- Wages and salaries
- Benefits and services
- Taxes at local, provincial and national levels
- Contributions to local charities

These give a practical appreciation of the contribution of steel producers to their local and regional economies, and ultimately to the Canadian economy as a whole.

The CSPA results are as follows:

Canadian Steel Producers: Economic Contributions (2008)

Direct Employment:	30,000
Payroll:	\$1.7 billion
Purchases:	\$9.3 billion
Transport/logistics spending:	\$1 billion
Taxes/govt remittances:	\$580 million
Community/Charity:	\$6 million/annual

The employment multiplier estimation was discussed above. Similarly, the impact particularly on local and regional economies is profound, and it is more complex than first appears.

Steel companies generate a base of demands from suppliers in the local economy, sometimes where none existed before. These businesses in turn, grow into expansive firms in their own right. A good example is the story of Evraz in Regina where the company began with no local industrial supplier base. Over time, it has produced such an industrial infrastructure in the local economy that local businesses have themselves expanded into international operations.

Local industrial services such as machining and fabricating were not available like in Hamilton when the company began. It was not there but now they are there. We developed contractors who later followed us to Iowa and Alabama.

Evraz now does research and development work for several laser cutting manufacturers working through product development trials for the agricultural machinery industry.

Steel Company Executive

What applies to machining shops and fabricators also applies to advanced engineering services, where new and expanded steel operations have expanded local professional business and technical services.

The following is an example from the pipe manufacturing industry.

We purchased a local company whose main business is to thread premium connections on casing and tubing for oil and gas drilling applications. There are two facilities. One is in Alberta where we have about 100 employees threading full length pipes and accessories. In Nova Scotia, we have a facility that provides local content. It is an innovative part of what is required to service the most complicated oil and gas wells. The premium connection is required in these wells to assure that well integrity is maintained during drilling and production in the most critical conditions. The R&D required to develop these premium connections is a competitive advantage for us.

We have combined the intellectual property developed by both to provide new solutions that will keep us well positioned to serve the most challenging wells in the future.

Relationships with local third party engineering firms have validated our product benefits statements. They have supported us through testing and other analysis so that the connections and steels that we have developed

for Canada were accepted in the market here and elsewhere.

Steel Company Executive

On the other hand, the recent downturn and the example of even a temporary closure of one steel mill can also rebound on other mills and other industries being serviced by material and technical suppliers as well as the local community.

There are suppliers based in the local community that are important: Contractors, services to supplement our internal activities, engineering companies.

Since another mill shut down it has created problems with the local supplier base. They may fold up or relocate operations to headquarters or other locations. At best they now have a local rep. It puts pressure on costs and services i.e. inventories, expertise and site visits.

Steel Company Executive

In the past year, any viewer of the media has seen the interdependence of the dense networks of auto industry OEMs with their multi-level supply chains. The same holds true for steel. The loss of purchasing, procurement spending and tax revenues would be similarly multiplied. So, too, are the additional community benefits that a major employer such as a steel mill brings to the community, through charitable donations, bursaries, community projects and facilities, and support for local community services through local taxes paid.

2.3 Death Star Scenario: What If No Steel?

What if there were no Steel Industry in Canada, or to look at it another way, what if the one we have were to significantly diminish or completely disappear? The results would be devastating in their dimensions and implications.

Canada has developed a significant steel industry which has grown in a close relationship with supplier and customer industries. This has generated wealth for all three parts of the steel supply chain. If we were now to begin to lose our steel industry, it is not only the steel industry and its communities that would decline. These other industries – supplier as well as customer – would in turn migrate away, minimally within North America, but ultimately to other regions. For example: if we didn't have the kind of auto steel capabilities in Canada that we do, would auto companies continue as much production in Canada or would production move closer to other, American or Asian, sources of steel supply? A good example on

the supply side is St Lawrence Seaway shipping. Steel is the largest user of the Seaway system, and without its volumes, communities from the mine to the mill would be affected; and the average cost for all users would necessarily rise

The recent temporary but extended shutdown of US Steel's facilities in Ontario may be considered a proxy for such an impact. Massive immediate job losses would be accompanied by crises for local businesses, a collapse of local public finances and the loss of a tax base for critical social and health services.

There has been a significant turnaround in the attitude of the community and their perceptions of the steel industry and the steel plant. They see that the mill makes money for the community. They only see it with the shutdown of the mill. They now see it as the basis of the industrial heart of the country. It is a chain reaction. The shut down showed the people in the region how much it was dependent on the mill.

A complete shut down would devastate the community. The layoffs have already resulted in layoffs of social workers while the numbers needing assistance has increased. The tax base has been hammered. Food Banks are empty of stock. It is severely straining the social safety net.

Local Union Leader

There would be further losses to manufacturing businesses which have symbiotic interaction with the steel industry, and to local public and supply chain suppliers that feed multiple industries but cannot afford the loss of a major customer industry if they are to remain viable for others.

An unorthodox but clear indicator of the implications of a steel shutdown scenario on the intricate web of economic, business and legal relations is seen in the listing of creditor parties from the recent Stelco bankruptcy proceedings. (See table of creditors on following page.)

If Stelco, at the time, represented about 25% of the capacity of the industry, we can be assured that the dimensions of a steel industry shut down would be at least 4X as complicated and probably 10X. It is a recipe for severe economic dislocation for the steel industry, for the industrial clusters of which it is an integral part, and for the support it lends to local and regional economies.

3. Steel: The Anchor of Industrial Canada

Throughout its history, the Canadian steel industry has co-developed

Stelco Creditors List

Stelco Bondholders	Mitsubishi Corporation	Charles Jones Industrial Inc.
GE Commercial Finance	Chubb Insurance Canada	Lafarge Canada Ltd.
Aecon Construction Inc.	Canadian Imperial Bank of Commerce	Mono Ceramics Inc.
Air Products and Chemicals Inc.	Comstock Canada	Minerals US LLC
Canada Steamship Lines	Kvaener Constructors Ltd.	Fleet Capital Canada
Massey Metallurgical Coal Inc.	EDS Canada	Ontario Power Generation Inc.
Cleveland Cliffs Inc.	United Steelworkers	PSC Industrial Services Canada
CAW	Stelco Salaried Retirees	Stelco Salaried Employees Association
GE Capital Leasing	Canadian National Railways	CIT Business Credit Canada Inc.
Inscan Contractors Inc.	Intragaz Inc.	D.M. Chrome Ltd.
Carmeuse Lime Ltd.	Baycoat Limited	CRO
Hayes Lemmerz International Inc.	CAFO Inc.	
RHI Canada Inc.	Harsco Canada Ltd.	
FSCO		

Source: CCAA Service List (2007)

with Canadian manufacturing. We would not have one without the other. Their economic and business histories are bound up with one another.

It is useful to think about the steel industry as having gone through four stages of development and having just recently entered into a new one.

3.1 Steel in Canadian Economic History

In 24 months from mid-2006 to 2008, the ownership structure and the familiar names of the steel industry Canadians had known for over 100 years, quickly disappeared. Another kind of steel industry took its place.

In this new era, Canada is seeing a new kind of globalized steel industry develop. The first Canadian steel industry was that of Sir John A. Macdonald and lasted from 1870 to 1940. The second stage was the wartime steel industry with C.D. Howe as Minister of Defense Production and government directly guiding the industry from 1940-45. The independent Canadian steel industry of the postwar steel industry saw its final demise in 2006-2008. In between there was an important shift in the mid 1970s as government support dwindled and

Time Period	Stage	Characteristics
1870-1940	National Policy Period	High tariffs Protectionism Part of National Building
1940-1945	World War II Steel	High Government Involvement Price and Product Setting Dollar-a-Year Men
1945-1975	Postwar Steel	Fully Integrated Steel Industry Development of Mass Consumer Products
1975-2005	NAFTA Steel	Trade Disputes Growth through expansion into US
2006 – Present	Global Steel	Global Product Offerings New capital and technology Global management benchmarking Global talent flows to and from Canada China as major player

Canadian producers moved to expand into the North American market.

We now have a Canadian steel industry that is integrated into a global steel industry for the first time.

On all previous occasions, Canadian steel has been benefited from supportive public policy. In Sir John A's time it was the National Policy of aggressive tariffs and duties. For C.D. Howe it was wartime production assisted by postwar incentives, including aggressive cost allowances, tax concessions and developmental natural resource policies. In the new era of global steel companies, and in a trade policy environment where historical forms of support are no longer allowed, the question is what sorts of public policies can best support this new steel industry, so that Canadian producers can maximize the opportunities.

3.2 Steel Manufacturing as Canada's Industrial Anchor

The Royal Commission on Canada's Economic Prospects (the "Gordon Commission") in 1956 put the issue of foreign ownership of Canadian industries at the centre of Canadian economic policy concerns for the next generation of Canadian politics. It listed the

steel industry at the top of the chart of the “good guys”. Canadian owned and Canadian managed, the steel sector was touted as proof that nationally cultivated industries could survive and thrive in the world economy. Not only were Canadian steel producers competitive in international markets, they were global innovators, as steel-making technologies engineered in Canadian mills were adopted by firms around the world.

The Gordon Commission devoted a special study to the steel industry. In its words, the decision to encourage the industry was a direct outgrowth of the National Policy of 1879. Up until then, iron and steel had entered Canada duty free or been subject to only nominal rates. By 1897, there was a complicated government policy of giving significant protection to the growing iron and steel industry -- what economists would call the “infant industry” argument. At the same time, items not made in Canada, or steel for use by certain manufacturers in their own plants, were allowed to enter duty free. As a result of government policy, by the outbreak of World War I the primary iron and steel industry had reached substantial proportions.

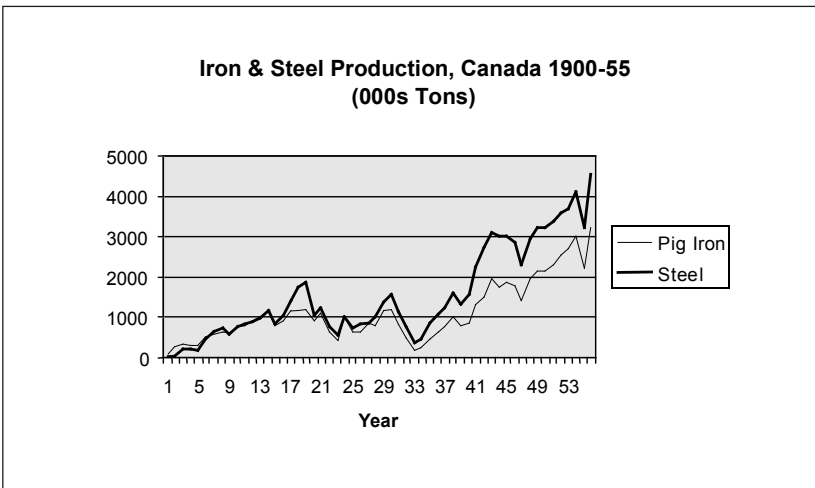

Source: Morgan (1956: 68)

However, the growth leveled off and came to a standstill between the Wars. The market for rails, upon which Algoma and Dominion Steel of Nova Scotia (Dosco) relied, had contracted with the completion of the third continental railway in 1915, marking the end of the major

period of railway building. On the other hand, steel-using secondary industries were underdeveloped. In the boom of the late 1920s, some of the types of steel most in demand – sheets and strip for the auto industry and structural steel for buildings – were not made here, or only in small quantities. Therefore imports held a very large share of the market.

WWII and the postwar period represented an entirely new stage of the steel industry. Steelmaking capacity in Canada by 1956 was 250% greater than 1939, a much larger increase than in the US where the increase had been 57%.

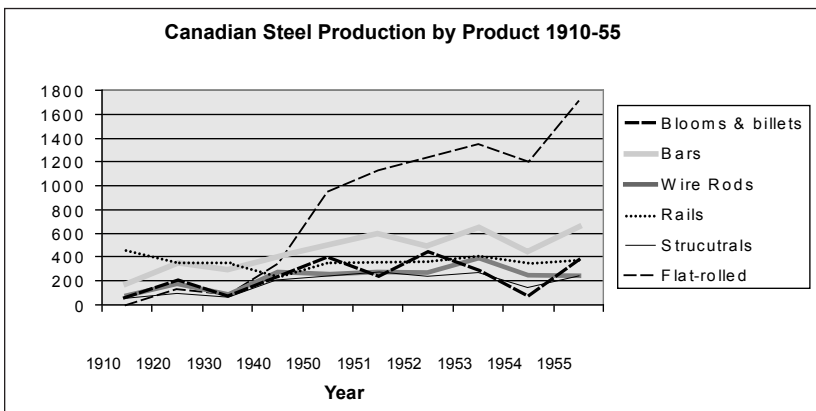

Source: Unit of measure 000s tons. Morgan (1956: 1090)

By the end of the Second World War, at the rolling mill level, the industry had undergone a transformation. Mills that formerly required a good deal of hand labour were increasingly mechanized, old facilities were replaced by larger and more efficient ones, and the range of products had been greatly extended. Before the War there was only one strip mill, a reversing mill, in Canada and most of the steel sheet was rolled in old-fashioned hand mills. By 1955 there were four strip mills – two continuous, one reversing and one ‘planetary’ – producing hot rolled sheet and strip in coil. New cold rolling mills and galvanizing lines had been added, as well as electrolytic tinning lines.

Production of hot-rolled sheet more than doubled between 1940 and 1955. Three quarters of the increase in capacity was in flat-rolled product. It constituted less than 10% of production in 1930, 20% in 1940 and 50% in 1955. Rails, which before WWI accounted for more

than half of total production, and 30% in 1930, made up less than 10% in 1955.

By the end of the Second World War, at the rolling mill level, the industry had undergone a transformation. Mills that formerly required a good deal of hand labour were increasingly mechanized, old facilities were replaced by larger and more efficient ones, and the range of products had been greatly extended. Before the War there was only one strip mill, a reversing mill, in Canada and most of the steel sheet was rolled in old-fashioned hand mills. By 1955 there were four strip mills – two continuous, one reversing and one ‘planetary’ – producing hot rolled sheet and strip in coil. New cold rolling mills and galvanizing lines had been added, as well as electrolytic tinning lines.

Production of hot-rolled sheet more than doubled between 1940 and 1955. Three quarters of the increase in capacity was in flat-rolled product. It constituted less than 10% of production in 1930, 20% in 1940 and 50% in 1955. Rails, which before WWI accounted for more than half of total production, and 30% in 1930, made up less than 10% in 1955.

Percentage Distribution to Steel Consuming Industries
(%)

	1946	1950	1955
Automotive	4.4	7.1	7.0
Farm machinery	4.6	4.6	2.4
Construction	9.9	12.6	14.3
Containers	8.6	9.2	9.3
Machinery & tools	5.4	4.1	5.7
Mining	3.6	4.7	5.4
Stamping	4.6	6.6	7.1
Utilities	1.1	0.5	0.7
Railway Ops	15.3	15.2	6.5
Railway stock	6.1	2.5	3.4
Shipbuilding	2.3	0.8	0.4
Distributors	13.7	11.1	13.5

Source: Morgan (1956: 90)

Still, as the following table shows, the Canadian industry was more heavily weighted to construction and railroads than to general manufacturing and particularly the auto industry, compared to the US or even the UK.

Distribution of Steel Using Industries: Canada, USA, UK 1949
(%)

Industry	Canada	USA	UK
Construction	28	17	13
Railroads	20	8	8
Machinery & equipment	11	12	23
Mining	8	10	8
Containers	8	9	7
Automotive	6	22	10
Electrical machinery	5	9	6
Shipbuilding	2	1	9
Other	12	12	16
Total	100	100	100

Source: Morgan (1956: 96)

The size of the Canadian market affected both the types of equipment used by steel mills and how they operated. Instead of specialized mills as in the US, numerous combined mills were used. Algoma, for instance, operated a combined bar and strip mill and its heavy rail and structural mill was interchangeable with its medium rail and structural mill. Equipment changeovers inevitably limited output. Stelco and Dofasco operated combined plate and hot-strip mills, the strip capacity standing idle when running plate. Dofasco's hot and cold mills were reversing, passing steel back and forth over the same rolls instead of through a continuous series of rolls set one after another. All of these operations involved smaller capital outlays but were less efficient. Roll changes added approximately 0.5-2.0 hours per ton of sheet or strip.

Overall, the Canadian mills were comparable to US mills at the blast furnace and coke oven stages but lagged in finishing operations. The production configuration of the postwar US industry had basically been set by the mid-1930s with the introduction of the continuous sheet mill that enabled the industry to supply the unprecedented volumes of steel required by the burgeoning mass production industries in auto and appliances. It would only be in the later 1950s that the Canadian industry would experience the final step up to mass production steel.

3.3 The Postwar Steel Industry

The story of Canadian steel from the 1920s to the 1970s is largely the story of Stelco.

Between 1931 and 1933 a modern metallurgical research laboratory was built by Stelco to supplement the small testing labs used previously. Also a new practice was begun whereby the sales force was given the aid of full-time technical experts to make periodic calls on regular customers. By going right into the customer's plant, technical sales personnel could discover their needs directly and deal with complaints in a far more practical way than was possible for commercial salesmen to do in discussion with purchasing agents.

Stelco's expansion in steel ingot capacity was not much larger during WWII than in the previous decade. By contrast, Algoma and Dosco expanded their steel facilities enormously with government aid during the war, after little or no increase in the previous thirty years. The greatest wartime changes in Stelco's plant were concentrated elsewhere: in steel rolling, ore handling, and in coke- and iron-making facilities.

Over its history to mid-century, Stelco had undergone two technical revolutions. The first created the company. Between 1910 and 1913 one company was fashioned out of five. Steel capacity was tripled. Electric power was harnessed for the first time to steel. A modern costing system was established along with an elaborate new capital structure. The four following decades saw the articulation of the new model of a steel company.

The second revolution took place in the 1950s and thereafter. Between 1945 and 1959 Stelco constructed continuous strip mills and galvanizing and electrolytic tinning lines that put the company for the first time on a par in efficiency with the most advanced flat rolling practices in the US. Stelco did more than catch up. Stelco engineers cut the heat time from 12-15 hours to 8 hours by blowing oxygen into the open hearth chamber. Subsequent lancing through the roof of the furnace cut it to as little as 5 hours, facilitated by a new generation of brick lining. Stelco also boosted its blast furnace productivity by a new sinter plant process.

Role of Public Policy in Steel Industry Development

While in the late 1920s imports accounted for 57% of the Canadian market, by the late 1930s this had fallen to 38%. Higher steel tariffs helped Canadian producers get a larger domestic market share and the system of Imperial Preferences gained them export markets in other British Dominions. Equally important factors were the decline in the

dollar after Canada abandoned the gold standard in 1931 and anti-dumping actions by the Department of National Revenue, particularly against the Europe Steel Cartel.

The steel industries of the United States and Western Europe had already expanded rapidly in the early part of the decade. As a result, world steel prices dropped steadily and foreign producers entered the Canadian market in increasing numbers. And a greater quantity of steel obviously entered the country in the new flood of imported consumer goods.

The old bugbear of the Canadian steel industry, the problem of small orders that required adjusting the rolls several times a day or every several days, was practically eliminated under the planning system of the wartime government agency for steel production (Steel Control) in Ottawa. A national steel budget was drawn up by Steel Control for 1942 and annually thereafter. It proved to be remarkably accurate in its forecasts and became an invaluable aid to the government and the steel manufacturers in making their expansion and production plans.

During the War, to assure adequate wartime production for military applications, the government offered to pay for and own new blast furnaces and open hearths which were to be wholly operated by the companies themselves. Both Algoma and Dosco relied heavily on this method for their rapid expansion. They each purchased new plant at nominal cost from the War Assets Corporation after the war. The most important device of all for spurring industrial expansion however, was the accelerated depreciation allowance. Investment in new equipment could be written off against profits in as little as three years' time, thus reducing the tax load in the early stages of the equipment's operation. In a sense, it was a form of government short term loan, with the hope of future profits generating future taxation as the security. This was the way Stelco financed almost all its increases in iron and steel capacity during the war. It became a spectacularly successful means of promoting investment during the far greater industrial expansion that Stelco and Canada enjoyed in the postwar period.

The postwar expansion was significantly assisted by capital cost allowances permitting the rapid write-off of new assets under the income tax regulations. Through this mechanism, the amount of retained income rose more sharply than earnings – more than 500% from 1946-50 and then by a further 50% by 1955. (Morgan 1956: 22)

The capital depreciation allowances not only boosted capital investment. They also allowed the Canadian steel companies to achieve net profits on sales at the top of the North American industry despite their smaller scale and market size.

Comparative Profits of Steel Companies (1955)

Company	Net Sales	Net Profit	Net Profit as % of Sales
Stelco	227.0M	21.8M	9.6%
Algoma	114.0	10.4	9.2
US Steel	4,097.7	370.1	9.0
Bethlehem	2,114.6	180.2	8.5
Republic	1,188.6	86.3	7.3
Jones & Laughlin	696.5	50.1	7.2
National	622.0	48.3	7.8
Youngstown Sheet	626.2	14.7	6.7

Source: Morgan (1956: 78)

The Role of Tariff Policy

The other important component of public policy – trade and tariff policy – was still an important factor of postwar Canadian steel success. Customs tariffs designed to promote production in Canada still had an impact up until the 1960s.

The all important tariff policy was skewed. Early tariffs tended to provide more generously for the protection of secondary iron and steel goods such as nails, wire and agricultural equipment – the primary needs of the Wheat Economy, while leaving the primary stage of production to fend for itself. There was some attempt to promote the domestic industry by supplementing the lenient tariff treatment of scrap and iron ore by adding a bonus of \$1-2 per ton for domestically produced iron ore.

The secondary processing and finishing end of the industry was where the early steel companies focused. The precursor companies which later consolidated into Stelco, Dofasco and Algoma had their origins as finishers of steel whose inputs – pig iron, steel ingots, plate and bars were imported from the UK, US and Germany. Using modern language and somewhat overstating their actual capacities, the early Canadian steel companies were value added processors, not primary steel producers.

Canadian Steel Tariffs (1955)
(\$ per ton)

Item	BPT ¹	MFNT ²	GT ³
Bars & rods	4.25	7.00	7.00
Plate	4.25	8.00	8.00
Sheet	4.25	6.00	7.00
Band & strip	7.00	12.75	17.00
Angles	Free	5.50	7.00
Shapes	4.00	6.00	6.00

Source: Morgan (1956: 83)

¹ British Preferential Tariff

² Most Favoured Nation Tariff

³ General Tariff

In 1958 the archaic structure of the Canadian steel tariff was drastically simplified into a basic rate of 5, 10 and 20% for the three categories of British Preference, Most Favoured Nation and General. The 99% rebates enjoyed by a great number of steel imports were entirely eliminated. However, by this time, some 70% of Stelco's production was sold within 200 miles of the plants that produced it.

3.4 C.D. Howe's Steel Industry

Howe's assessment of the industry was that Stelco assured Canada had a broad and well-established capacity in finished steel. Firms like Atlas offered specialized output in alloy steel. Dosco, Dofasco and Algoma offered the potential for a solid base at the primary level.

Both industry and government leaders expected and planned a quick wind down of direct government controls in steel upon conclusion of the war. However, the 1946 Steel Strike in Hamilton and US labour and industry difficulties led to a reversion to direct government controls in 1946-47. The Steel Controller was empowered to assume direct control of company facilities. Unlike in the US, where government-industry relations regressed into a long slide culminating in the famous 1962 confrontation between John Kennedy and the US steel industry, in Canada a renewed consensus emerged, not without some friction, between Big Steel and government in the late 1940s.

Vision of an Integrated Steel Industry

In the postwar period, Howe concluded that certain structural changes were still required for the Canadian steel industry. Canada

would be best positioned by a maximum degree of steel self-sufficiency. Between 1944 and 1947, Ottawa had granted \$1.4 billion in special depreciation allowances. The late 40s consensus in steel was that if in the judgment of the industry, adequate capacity for peacetime needs existed but the government felt increased capacity was required for national defense reasons, then the funding of the additional capacity should be the responsibility of the government, not the industry.

This was the rationale for the renewal and expansion of assistance to the steel industry in the period during the Korean War. In 1951 the Defense Production Department under Howe began 'end use' rationing of steel. Under an assumption that US supplies could not be assured, major increases to capacity in Canada were subsidized. Algoma for instance, used the new allowances, plus a loan from General Motors, which was concerned about supply during the 'steel famine' in the US, to hugely expand and modernize its cokemaking facilities, blast furnaces, open hearths and structural mills, as well as adding a new finishing mill. The company broke into the lucrative auto sheet market for the first time. By 1954, Algoma could boast that 80% of its production was coming from equipment installed since 1942.

Postwar Steel Innovation: BOF, CCM

The basic industry production configuration from 1900 onwards was framed around the Open Hearth Furnace (OH) for steelmaking and the Wide Strip Mill for rolling product. This remained so for fifty years from the mid 1920s to the mid-1970s. The Japanese steel revolution began in the 1950s with the introduction of a fundamentally different production technology paradigm – the Basic Oxygen Furnace (BOF) and the Continuous Casting Machine (CCM).

Canada was an early adopter of this new technology paradigm, in some cases doing so even before the Japanese. Details of the Canadian path are given in the History Appendix. It will surprise many, but the greatest expansion in steel capacity between 1945 and 1965 came in Canada followed by Italy, not Japan.

Canada had a rapidly growing market in consumer goods and resources. Companies had strong balance sheets and the tax system gave major incentives for large scale capital expenses. The Canadian steel companies embraced the opportunity and policymakers cheered them on.

The US by contrast, missed it. While the fundamental change in the technology of steelmaking was gathering momentum in Japan, the US industry was re-installing some 45 million tons of the older OH capacity in the late 1950s and 60s. Having re-invested in the old technology, the US steel industry made one of the most costly mistakes in business history. It would not be able to compete successfully with the new Japanese steel industry, a cruel fact that would not be fully evident until the mid-1970s.

The full dimensions of this shift is discussed below in Chapter 6 on Steel and the Information Economy.

4. Canadian Steel in a Globalized Industry

The steel industry became globalized in an unprecedented way during the first decade of the 21st century. Most clearly this has been seen in Canada where all the formerly independent steel companies were the subject of takeovers by foreign companies.

Who were the acquirers in the ownership change in the Canadian steel industry? The following Table provides many notable ownership changes in the Canadian steel industry.

Who They Were	Who They Are	Head Office
Stelco	US Steel	USA
Dofasco	ArcelorMittal	EU
Algoma	Essar	India
Ipsco	Evrz	Russia
Co-Steel	Gerdau Ameristeel	Brazil
Stelco (Quebec) and Sidbec	ArcelorMittal	EU
Algoma Tube	Tenaris	EU
AltaSteel	Scaw	South Africa
Stelpipe	Lakeside	Canada
Courtice	Gerdau Ameristeel	Brazil
Prudential Steel	Tenaris	EU
Quebec Iron & Titanium	Rio Tinto	EU

The following is a brief description of the largest steel companies.

ArcelorMittal

ArcelorMittal is the world's largest steel company, headquartered in London with operations in more than 60 countries. It is present in all

major global steel markets, including automotive, construction, household appliances and packaging. It is a leader in R&D and technology development and has its own supplies of raw materials and distribution networks.

US Steel

United States Steel Corporation is headquartered in Pittsburgh, with major production operations in the United States, Canada and Central Europe. The company manufactures a wide range of value-added steel sheet and tubular products for the automotive, appliance, container, industrial machinery, construction, and oil and gas industries. It is a leader in both process and product technology and has three research and development facilities.

Essar

Essar Global is a private company headquartered in Mumbai with subsidiaries in steel, oil and gas, power, communications, shipping and logistics, and construction businesses primarily in India, Canada, and the United States. They view Algoma as a platform for growth in the North American market. They produce plate, sheet, blanks, and welded shapes and profiles.

Evraz

Evraz Group is the largest producer of steel and steel products in Russia. Its North American headquarters is in Portland, Oregon. Evraz has focused on the plate market and pipe business in North America and is the leading rail producer globally. It is also an important player in the world vanadium market.

Gerdau

Gerdau Group is headquartered in Brazil. It is the world's 14th largest steelmaker and the largest producer of long products in the Americas. Gerdau Ameristeel is the fourth largest overall steel company and the second largest minimill steel producer in North America. Its products are used in a variety of industries including construction, automotive, mining, and cellular and electrical transmission.

Tenaris

Tenaris is headquartered in Luxembourg. It is a leading supplier of tubes and related services for the world's energy industry. Its principal products include casing, tubing, line pipe, and mechanical and structural pipes. It operates Tenaris University which gathers and

codifies the knowledge and best practices within the company's operations.

The purchasers of Canadian steel assets came here for a reason. They spent billions of dollars because they believed there was a future opportunity.

They saw Canada as an entree into the NAFTA steel market.

They had never been in the Ontario manufacturing sector before so it was a new market for them. It was a new customer base.

They were also protecting their interests in a raw materials base as well as a source of semi-finished slab. There were also iron ore reserves.

They now have an additional millions of tonnes of slab capacity .They were solidifying their supply chain as part of their global network of production facilities.

They had seen the potential in energy markets.

They could avoid the cost of a green field investment in gaining this incremental capacity.

Steel Executive

We cannot get into the heads of the buyers, but the above points would appear to provide a reasonable summary of their primary motivations.

All major Canadian producers are now part of large globalized operations. The change has been accompanied by benefits such as access to managerial talent, technology and capital pools.

4.1 Access to Capital and Technology

The traditionally independent Canadian steel companies were absorbed in the recent wave of global consolidation in the steel industry. However, this is not the same story as Pittsburgh in the 1980's, which saw its steel producing facilities entirely disappear over the course of a decade. All of the Canadian steel facilities are still in place and active (but for labour disputes), even allowing for the recent economic downturn. However, it is now a very different kind of Canadian steel industry than its predecessor.

This development was not a total surprise to Canadian steel producers. Quiet discussions were going on in corporate Canadian boardrooms a decade before the event.

It was inevitable. Years ago, our CEO said that we had to grow to the 20 million ton level to be viable in the future.

Small steel companies couldn't survive in such a cyclical industry. It was an issue of scale. When steel went into a major downturn, accompanied by dumping, the small companies are forced into a race to the bottom. They could only hold on to their customers by cutting prices. They did so but it took them to the brink in terms of cash flow, no investment, cuts, loss of talent.

Ex-Stelco Executive

The OECD Steel Committee gives a broad summary of the major and sometimes competing theories for the dramatic consolidation of the global industry in recent years. (OECD DSTI/SU/SC(2007)3/REV1)

The Fixed-Cost Hypothesis

According to this view, the steel industry, whose firms have a high proportion of fixed costs to total costs, is prone to periods of harmful price competition during market downturns. During periods of falling demand, if steel firms scaled back production to equal marginal revenue to marginal cost, they would quickly suffer profit losses since fixed costs per unit of output would rise sharply as production fell. To lower their unit costs, steel producers were tempted produce more and gain market share, even when the result was to lower their prices. As most producers faced the same incentive structure, the market price would fall, steeply at times, in response to the growing supply surplus in the market. This would result in detrimental losses and bankruptcies, a situation that steelmakers would ultimately try to avoid by combining their companies. Thus, greater consolidation is a way to reduce price volatility and achieve higher profits.

This argument appears plausible if steel production were highly concentrated geographically with little or no trade internationally, as was the case a century ago. Production restraint in order to boost prices would thus not attract significant competition from steel imports. Today, steel production is dispersed across all parts of the globe and some 40 per cent of it is exported. To a certain extent price divergences can be sustained because imported steel is not a perfect substitute for domestic steel. Steel consumers may prefer locally produced steel due to, e.g., the relatively short time needed to deliver it to customer manufacturing plants, and thus be willing to pay a premium over imported steel.

Economies of scale

Related to the fixed-cost hypothesis is the idea that steel industry

consolidation takes place because steel firms strive to take advantage of economies of scale. In other words they achieve lower unit costs through higher production. If economies of scale are to be achieved, smaller steel plants have to be replaced by larger plants. However, consolidation in the steel industry often occurs through the acquisition of additional plants, which does not generate economies of scale in production. Therefore, economies of scale, alone, do not seem to be an important explanation of consolidation.

Synergies

Even though consolidating firms may not benefit from economies of scale in production, by coordinating the assets, know-how and management skills of the merging firms, the combined steel firm is more efficient and thus enjoys superior output/cost combinations. Thus, synergies require the sharing of merging companies' assets, which allow the combined company to produce as much or more for a given cost. In the recent large mergers, the synergies cited relate mostly to marketing and product development, R&D and purchasing. Combined companies may benefit from lower raw material costs through greater negotiating power over suppliers, from managerial efficiencies which reduce corporate staffing needs, and lower costs of distributing steel if the various distribution systems can be integrated well. Such synergies can be significant. In the case of Mittal Steel's acquisition of Arcelor, Mittal expected cost reductions to reach USD 1 billion within three years' time. Typically, the synergies targeted in steel company mergers are around three per cent of costs.

Optimizing the allocation of production

Synergies are, at least in theory, relatively easy to achieve. However, whether management can properly identify and implement these synergies is another question. Even when synergies are not feasible, costs can be reduced by rationalizing production, i.e., by shifting steel production from high-cost mills to more efficient mills following a merger, so long as the more efficient mills have underutilized capacity.

This type of efficiency gain is different from a synergy, since the merging partners' assets essentially continue to be used separately following the merger. This rationale for merging has been cited in numerous recent deals. For example, Tata Steel's offer to buy Corus was based, at least partly, on the cost efficiencies of Tata providing slabs produced in India from captive iron ore at up to half the cost of

UK produced slab. In the Evraz-Oregon Steel Mills merger, costs could be lowered by Evraz supplying slabs produced in Russia at low cost using the company's own iron ore at Oregon's plate mill. This is envisaged to boost profit margins for Oregon's plate and pipemaking operations. Moreover, ThyssenKrupp, Baosteel and Dongkuk are involved in slab production in Brazil, while Posco and Mittal Steel have projects in India.

Steelmaking raw material prices have surged in recent years. For example, the price of iron ore was doubled compared between 2005-07, slipped back somewhat in the Recession but are expected to double again in 2010. Coal prices have also increased noticeably. As a result, many mergers and acquisitions are being driven by the desire to produce basic steel in low-cost regions near raw materials, yet maintaining or accessing geographical proximity to major consuming markets. A prime example is the recent bid for Corus by CSN and Tata Steel. CSN's rationale was that it could supply all of Corus' iron ore needs through its own mine in Brazil.

Greater flexibility in labour contracts

Other cost benefits from acquisitions can result when the acquiring firm is able to lower labour costs by renegotiating more flexible contracts with the employees of the acquired firm. This has been the case particularly in the United States, following a wave of bankruptcies in 1998-2001 which forced unions to accept lower wage costs. In the case of International Steel Group's acquisitions of the LTV Corporation, the company negotiated a labour agreement with the United Steelworkers allowing for greater outsourcing activity and fewer job classifications, as well as a restructuring of compensation and pension plans. Allowing workers to perform a wider array of duties than before and for outsourcing during peak periods of demand ultimately boosted labour productivity and thus helped to reduce unit labour costs.

Attracting Capital

For a long time, capital markets have been reluctant to commit resources to a steel industry suffering from chronically low profit rates, high costs, excess capacity, and at times bankruptcies. As a highly fragmented industry, the steel sector lacked the capital access to invest in new technology and in new products, to compete with alternative materials, to attract management and technical talent, and

deliver what customers require when they require it. Thus consolidation may be a means of permanently increasing profitability in the steel industry and help it attract capital for innovation and future growth.

Dynamic efficiencies

Mergers in the steel industry could, in theory at least, give rise to so-called dynamic efficiencies. These relate to efficiencies that could be achieved through research and development or sharing knowledge and skills which lead to the development of new products, production processes or improved product quality and service. Consolidation may encourage steel companies to engage in more research and development activity, because there are fewer competitors to free ride on the benefits generated from their innovations.

What has been the impact of globalization on Canadian steel operations and future directions?

The most immediate, practical impact has been significant cost savings, reportedly in the 10-15% range in some cases, through global benchmarking of best practices within the new global steel management. These range from technical operating, engineering and procurement practices to human resource policies. It has also been accompanied by circulation of technical talent both inward and outward bound between Canadian and international operations. This has now become embedded in standard management practices and procedures including regular monthly and quarterly meetings and conference calls, along with formal annual reporting and quantitative measurement. Management practices have become much more systematic.

The second and more important long term factor is the change in access to capital and technology. Access to capital has significantly increased and decision making on capital expenditures has been significantly speeded up, say managers who worked under the old system as well as the new.

The following are variations on the same theme from three different steel companies:

There is greater access to capital but it is competitive. Things like environmental regulations are a factor. Best practices have reduced overheads. There is more leverage with suppliers. We have become a more sophisticated company.

Capital access is much better. We have dramatically improved our scrap business, a new reheat furnace, new cold bar sphere, other upgrades. This started with the previous ownership but accelerated with the new owners. But there is competition within the organization. We have to get the benchmark returns.

We have greater access to capital. But we have to compete for it. There are also indirect effects such as in auto and because of the rise of the Canadian dollar. Buy America has important implications. It creates uncertainty so investment flows to the USA and not to our projects.

Steel Executives

Also, access to technology has increased under globalization. The Canadian industry in the previous 20 years had become increasingly reliant on international technology licensing and transfer to try and stay abreast of the latest and greatest in steel technology and applications. However, those who worked with technology licensing in the past are of the view that the vendors never provided the absolute best of breed solutions.

We only ever got about 2/3 of the knowledge. We never got the best talent and latest stuff. We would get 590 but meanwhile the other companies had moved on to 780. We never got what they contracted and paid for.

There is fuller access now.

Ex-Steel Executive

Under licensing, the Canadian producers were always trying to catch up and never believed that they were getting all that they paid for. Now they believe that they get full access to the complete range of leading edge technology and associated know-how from around the world.

We have expanded our product presence southward to South America through synergies with the global company. It has opened doors for us with related business segments we have not been in previously.

Steel Executive

We have an active policy on innovation but without the technology licensing dimension. It is indigenous technological development within the global firm.

Examples include:

Packaging: microwavable steel cans. And new openers.

Construction: Working with the Quebec provincial government on new safety barriers, drawing on EU experience.

Organic coating: chrome free from the EU

Steel Executive

However this improved and expanded access to capital and technology comes at a price. The management of Canadian operations are in an intense competition with other facilities trying to get their projects accepted and funded by head offices. For this reason, there is an even greater emphasis on trying to frame public policies that best support future investment decision-making in the industry. Ideally, there should be a natural, supportive alliance between local steel management teams and Canadian policy makers.

Another major impact of globalization of the Canadian steel industry is a much more rapid balancing of supply and demand. Steel has been and will remain a very cyclical industry. It makes an intermediate product. The decisions of others affecting auto demand or capital investment decisions hugely impact the net demand for steel. These normal business cycle factors have in the past however, been accentuated by movements in steel trade. Downturns in the economy have often been accompanied by dumping of imports, further depressing steel prices to destructive levels and wreaking havoc with capacity utilization, viable pricing and layoffs.

There is evidence to indicate that the globalization of steel has had a dampening impact on these destructive tendencies (i.e. the Eastern European operations of a global steel company will not be allowed to put its North American operations into bankruptcy by dumping).

The final impact of globalization on Canadian steel has been an important shift in market perceptions so that virtually everyone now sees Canadian steel as operating in a single North American or NAFTA steel market. While this change of perceptions is important and there has been a major reduction in intra-North American steel trade disputes, the trade laws and regulatory regimes in North America are not yet completely aligned with the new market reality. There are still differences in the way steel companies and their complaints within the member countries of NAFTA are treated.

4.2 Restructuring of World Steel: China vs Brazil

It is obvious to any viewer of the media that the steel industry has

undergone a profound change in recent years with a huge wave of mergers and global consolidations. Within this general theme, there has also been a major change in restructuring and locational decisions for steel facilities and capabilities.

The fulcrum of global steel development is raw materials and energy. It rises and falls on the cost structure. This follows the other metals groups like globalization in aluminum.

The key is Brazil. It has this incredible base in low cost, high purity iron ore.

Steel Consultant

The 1990s saw a major restructuring of the industry in which steel companies looked to disaggregate their operations horizontally (i.e. focus on what you are good at). Now the industry has been re-verticalized. The trigger was the impact on steel prices and the cost of raw materials accompanying China's emergence as the leading steel power in the world. This new and challenging story was told by a group of international steel engineering consultants.

Twenty years ago the companies disaggregated (do what you are good at) then with the rise of China and shortages/rising prices for raw materials, there was a wholesale re-aggregation and consolidation in the industry. It has turned around 180 degrees.

Steel Consultant

Vertical re-integration allows companies to better control their costs.

Ownership of iron ore and control of costs became strategic. Companies have leveraged back to the iron ore stage. It is the big competitive advantage. It is where Brazil has such an advantage. It has the cost advantage in iron ore and plays it through to the slab stage.

Steel Consultant

Increasingly, the key variable is accessing the lowest possible raw material costs, principally iron ore. Globally this has raised Brazil's profile for investment decisions. Brazil may actually be a more important steel restructuring scenario in the coming decade than China because the Chinese basically have to import everything to support their burgeoning steel production. The Chinese and Europeans have focused new capacity investment on Brazil at least for raw material processing up to the slab stage.

China may not be such a big story because it has to import everything and has such bad infrastructure.

Steel Consultant

This has also led to a shift in locational decision-making. The thrust of locational decisions is to locate basic production facilities close to the cheapest raw material inputs. Finishing capacities can then be located wherever the end user markets are located.

There is a New Steel Paradigm

The old view was that raw materials were ore and coal.

The new view is that raw materials include right up to the slab and even hot band stage.

The end user only comes in at the finishing stage. You locate that close to the market.

Brazil is positioned to play this strategically but isn't there yet.

Steel Consultant

The big guys with ownership and control of resources will be able to choose where their intermediate products are positioned.

Value added will be assessed at each step in the chain of manufacturing and assessed in terms of the capital required.

Who would want to own a galvanizing line?!

Control of raw materials effects the selection of grades. The sophistication of the final products are directly related to the sophistication of the material inputs.

Steel Consultant

There are two significant implications of this shift for Canada.

First, we do have significant iron ore deposits in Quebec and Labrador to more than meet our demand, although they lag Brazil in quality. Second, in the past raw materials simply meant iron ore and coal, but now steel companies regard raw materials as including everything up to the slab stage and perhaps even the hot-band stage. This may have dramatic implications for the nature and scale of North American steel facilities in the coming decade. The test case of this is being played out in the new Thyssen facility in Mississippi where all the raw materials up to the slab stage will be imported and finishing then done to feed the Southeastern auto plants.

4.3 New Technology and Talent Flows

Interviews indicate much more access to leading edge steel technology under the new ownership paradigm and a much greater circulation of

talent between steel facilities here and abroad. It has flowed both ways, in terms of benchmarking of best practices and talent flows.

5. The Steel Cluster

To fully understand the importance and contribution of the steel industry to the Canadian economy, the industry has to be understood in the context of the cluster of industries of which steel is an integral part.

5.1 Natural Steel Manufacturing Cluster

For steel producers there is a natural steel ‘cluster’ of steel companies and their manufacturing customers who have to locate in reasonably close proximity because the product itself, in whatever shape, has heavy transportation costs. The freight cost variable is the fundamental determinant for immediate cluster behaviour in steel.

In this scenario the steel mill is a hub and other businesses want to locate around it. There is also a segmentation of customers around the mills. For those using commodity grades, freight costs are the economic dividing line, but for those pursuing the value added grades, they need the steel mill’s technology and engineering talent.

The steel-manufacturing cluster phenomenon is the site of traditional connections between mills and heavy manufacturers such as automotive and appliance fabricators in Southern Ontario. In other regions, the different structure of the economy drives a different outcome. For example, Evraz in Regina developed to serve the needs of oil and gas and heavy equipment industries associated with the resource economy of Western Canada.

Engineering and process improvement stories abound in the history of interaction between the integrated steel mills and the manufacturing OEMs. Many relate to basic metallurgy, because so much of the final steel product attribute set is determined by the original metallurgical and processing parameters in the melt shop of the steel mill. This is where producer-user interaction has been closest, and where their co-dependency is most evident.

Historical patterns of supply are evolving in accordance with changes in advanced manufacturing in general.

In the new manufacturing model we are largely operating supply chain contracts much like the auto industry. Most of the steel is consumed by Tier 1 suppliers within the chain.

In the classic manufacturing days, many of our businesses were vertically integrated. They bought a lot of materials including steel. The 1990s was the turnover point. We now focus on building our IP, outsource many things and build a robust supply chain. It is more or less like the auto supply chain. Final assembly might or might not be in-house.

Manufacturing Executive

The heart of the issue derives from the model of the auto industry supply chain, the lead customer for steel and the reference point for modern lean production.

We use hundreds of thousands of tons of flat-rolled steel.

The auto OEM Resale programme dominates. In most cases, OEMs purchase the steel, seeking bulk pricing from the steel mills and distribute the steel to the Tier 1 parts suppliers. From the mid 1990s this changed how we do our business with the steel industry.

There are two channels of steel supply: Resale is 65%, Non-ReSale is 35%.

Tier 1 Auto Supplier Executive

This new approach to manufacturing and supply has created different and not always welcome relations between management of the Tier 1 suppliers who manufacture the auto parts and management of the steel mills.

On the ReSale, we get involved with logistics, quality, etc. Everything but the purchase transaction. The relationship with the Mills is good but not as good as if we had the whole transaction in our hands. He who pays the piper ... The system dilutes our relationship and leverage with the Mills. On Non-Resale steel we have the service centres between us and the Mills.

We used to deal with the Mills for Canadian steel on its own terms and deal directly in our own relationship with Mills. Now the mills are not locally owned, decisions are made elsewhere.

Actually in 2008, it sheltered us from having to manage the volatility in steel prices and markets.

Tier 1 Auto Supplier Executive

Nonetheless, as R&D responsibility has devolved from the auto OEMs to the Tier 1 suppliers, they feel the need and have the desire to establish more developmental relationships with the mills in the future.

For advanced parts manufacturers, technical interaction is the most important factor particularly for HSLA or Dual Phase steels. We work on

very specific applications. There is no recourse if they are out of spec. The steels are prototyped from the design stage forward, which specifies certain grades of steel e.g. for certain stiffness characteristics. This is the importance of locally sourced steel.

We want to work directly with Mills on R&D, cost reductions and moving new grades to reduce costs.

Tier 1 Auto Supplier Executive

It seems that there is a substantial future for steel mills within their natural economic clusters, although there is a rebuilding job to be done to work through the complex issues in the new manufacturing supply chains in order to be able to take advantage of it.

5.2 Steel Technology Cluster

Policymakers at all levels of government now use industrial clusters as their reference point, a major policy shift deriving from the work of Michael Porter of Harvard Business School in his 1985 book *Competitive Advantage*, and his subsequent work *The Competitive Advantage of Nations* (1990). Porter's insight and argument was that competitive advantage did not flow to countries or to firms but to groups of firms (producers, customers, suppliers) that clustered to mutual advantage. The clear implication is that location matters in economics and economic policies.

There is a Canadian Steel Technology Cluster. It is comprised of the steel producers and their suppliers of material and professional services (engineering, logistics, etc). It is historically centred in the region around Hamilton but extends to other provinces.

To illustrate the importance of clusters consider that contrary to many news reports and conventional wisdom, the steel story is not over in Pittsburgh. The stylized facts are that while the steel industry has lost its mills, the jobs have been replaced with health sector jobs at the Carnegie-Mellon Health Complex. Some suggest the same for Hamilton with Hamilton Health Science Centre prospectively making up for the loss of the steel industry. This however is not true for Hamilton, it is not even true for Pittsburgh.

Although Pittsburgh lost most of its steel-making *capacity* from the 1980s onwards, it did not lose its steel-making *expertise* (Treado 2008). The importance of this for jobs will be explained in some detail. Furthermore it should be noted that Hamilton has retained steelmaking capacity as well as steel expertise.

The Steel Technology Cluster is made up of firms that provide a diverse array of products and services as part of the supply chain of the steel industry. This supply chain can be divided into four main components:

1. Production equipment used by steel mills;
2. Engineering services that assist mills in the selection, design, and upgrading of that equipment;
3. Parts and supplies needed to keep that equipment operational; and
4. Raw material inputs to the production process.

The Cluster employs over 12,000 people. Average income is \$56,000. This represents a 50% increase over the average regional wage of \$36,051 and a 10% increase over the average wage for Iron and Steel Mills in the region of \$51,000 in the past.

Contrary to the assumption about the disappearance of steel, the intermediate suppliers of goods and services to the steel industry have managed not only to survive the loss of steel-making capacity in the region, but to transition successfully into an integral part of the global steel supply chain.

The development of the Steel Technology Cluster arose from the process of de-verticalization of the steel industry. De-verticalization of steel production has had two main effects on the role of intermediate suppliers. First, they have expanded their role in the supply chain to include services as well as products, such as the bundling of material handling with the supply of raw materials. Second, they have developed a network of relationships with each other in order to coordinate the supply of products and services to a global (rather than local) industry. Although geographic proximity to the customer is no longer as critical to the suppliers, geographic proximity to other suppliers has risen in importance.

It is not easy to quantify and identify the Steel Cluster from conventional statistical sources. For instance, there is no simple Statscan category for a steel technology cluster. However, in recent academic studies a proxy for the steel technology cluster has been found in the annual Directory of the American Institute for Steel Technology (AIST). This is an industry source where firms self-identify as producers and suppliers in and for the steel industry.

The 2009 AIST Directory includes separate listings for Canada. On that basis we can say that there is a Steel Technology Cluster comprising 106 firms across the country, largely but not exclusively located in Ontario and Quebec.

Not surprisingly, the largest concentration of steel manufacturing activity is in the Hamilton region. However the second largest steel manufacturing and fabrication concentration is Edmonton.

Industrial clusters in a globalized economy do not subsist as islands in themselves. They exist in a series of nested scales. The Steel Technology Cluster is embedded in a larger Materials and Manufacturing cluster.

The economic performance of industrial clusters is traditionally measured by their relative export performance. On this basis, the Canadian steel industry has historically performed very well compared to other manufacturing industries, even allowing for a troubled history of trade disputes with the United States.

Analytically and policy-wise, the economic performance of clusters has been strongly correlated with the phenomena of inter-firm knowledge flows as well as the impact of high skilled and specialized local labour pools.

In the following section, this study draws on complementary research on knowledge networks in the steel, auto and advanced manufacturing industries in Ontario sponsored by the Toronto Regional Research Alliance (TRRA¹).

A recent Report finds close connections between innovation and knowledge transfers within the new dynamics of globalization (Birnbaum, Cohen, Harris and Warrian 2009). In the new economy, instead of independent firms and stand alone industries like steel, as we have previously known them, we now have local industrial capacities embedded in global supply chains and knowledge networks. It is in fact local knowledge networks within private firms with linkages to public research infrastructure that fundamentally link local capabilities with global supply chains. It also suggests that public research infrastructure has the opportunity to play a more significant role in innovation than in the past. This is ironic because traditional local R&D capacity within the local firms has been reduced.

1. The Toronto Regional Research Alliance is an association of leading research universities, teaching hospitals and laboratories that seeks to promote more effective links between research capacities and investment opportunities in the greater GTA.

The automotive, steel and advanced manufacturing sectors differ significantly in terms of how innovation and knowledge are developed, shared or used. This is chiefly determined by the structure of each industry and where a particular firm sits in the industry supply chain. Factors such as the nature of supplier relationships, the ownership pattern of the industry and the nature of the product itself play a large role in influencing how new products and services are developed and how R&D resources are allocated.

In the automotive sector higher level innovation and long term R&D in this sector are conducted by the Original Equipment Manufacturers (OEMs) who develop design specifications which are provided to the Tier 1 suppliers and parts manufacturers. At the Tier 1 level, companies engage mainly in innovation to meet customers' design specifications and carry out incremental product improvements in areas identified by OEMs as priorities e.g. weight reduction as a step toward fuel efficiency. When these manufacturers develop innovations independently, this is regarded as a strong competitive advantage over other parts suppliers; however, it is not customary to conduct such work outside of contract work.

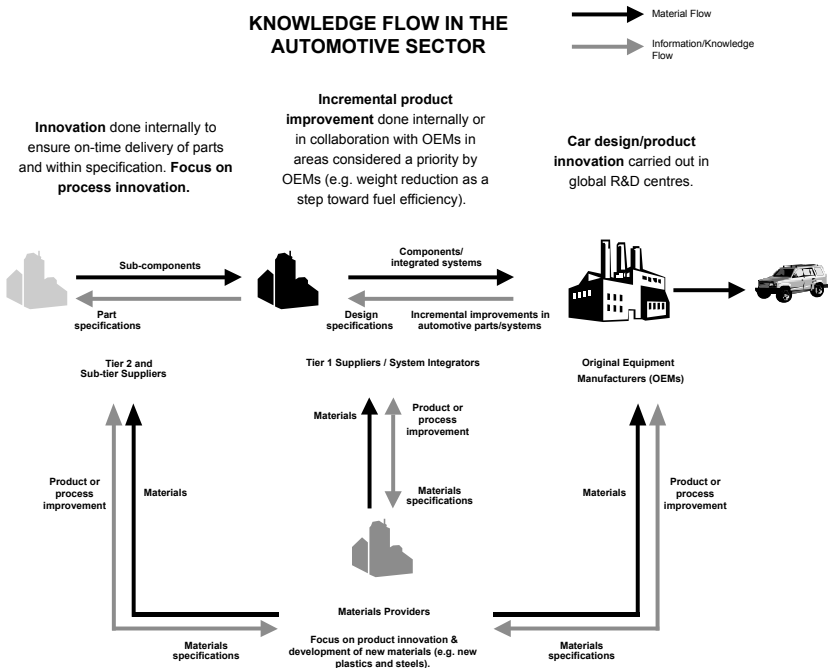

Sub-Tier 1 suppliers tend to focus on delivering parts on time and within specification to their customers. They are therefore less likely to consider game-changing product innovation as a business strategy and are more inclined to develop process improvements only. Materials suppliers often work with both Tier 1 suppliers and parts manufacturers to carry out R&D in order to meet design specifications, deliver improvements in OEM focused areas and facilitate process improvement for parts manufacturers.

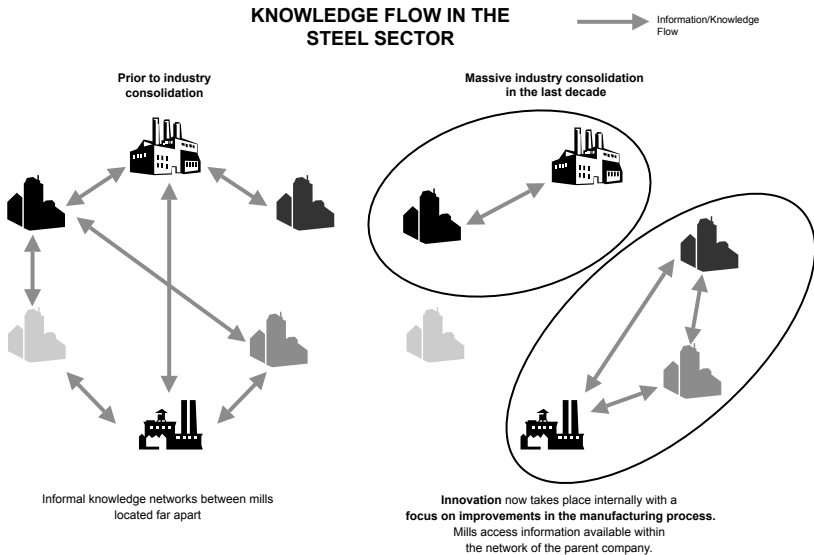

The most important finding regarding the steel sector is the dramatic change it has undergone in the past decade due to the consolidation of the industry. This has resulted in a great change in how knowledge flows within the industry. Previously steel mills would access knowledge through informal networks of managers and engineers from a variety of other mills. This might be supplemented by formal technology licensing and intellectual capital (IP) agreements.

Now, with consolidation, mills primarily talk to other mills within the same parent company. This has resulted in a change in how local mills undertake research. Steel mills in Canada, which were behind in technology to Japanese and European mills, have begun to integrate vertically and access the information and technologies directly available within their parent companies' network.

Well the industry has become heavily consolidated and there are actually fewer companies to pay to actually participate. And they are all that much more protective of whatever technical developments they are undertaking.

That's one of the biggest competitive advantages that we have is the network. We have [a lot of plants] worldwide. So chances are the problems that I have, they have been fixed in another place.

Q: "How does the company participate in research consortia?"

A: "These two industries used to be very open – subtle players. We're all a lot more cautious"

Q: "And that's specifically because of the consolidation?"

A: "Consolidation just makes it a lot more important. For instance in the past so many mills could share your ideas without even competing. Now it's different."

Q: "Because that mill is owned by someone local?"

A: "Because there was only one mill – today is different. If I share an idea with a small mill in the southern United States this is going to impact our sister plant, because we have another plant there."

Steel Executive

Another key finding was that the steel sector focused most of its innovation on the process side. This is because at the end of the day steel for most people is still a commodity where the number one competitive advantage is price. While coatings and light-weight steel are important to markets such as automotive, in the end you sell steel because of a competitive price and an acceptable level of quality. The reality of steel as a commodity business dictates that rather than focusing energy on improving a product, research tends to focus on ways to make steel cheaper and to process it faster so as to be able to outbid competitors. Steel's status as a commodity forces innovation on the process side.

He said the only way you guys are going to survive in Canada and the future is if you become special. You've got to get away from steel as a commodity. You know what it means for me? If I want to become a specialty mill it means that most of my equipment is going to have to change because a mill that makes specialty steel – like stainless steel does not use exactly the same equipment. If I have a plant that's capable of making 1 million tons, how can I get a market for special steel for 1 million tons.

Steel Executive

Skill or efficiency is hugely important to be able to manufacture at cost competitively. Quality of service to customers is obviously important, especially in automotive. Automotive measures quality in terms of parts per million rejects and rates their suppliers on a monthly basis based on that.”

Steel Executive

This focus on process side innovation was reinforced by the relationship with customers. Customers from automotive to construction also tended to view steel as commodity and this restricted the steel sector's ability to develop new products. As the quote below illustrates, many customers are not willing to pay a price premium or be reliant on only one producer and this provides a disincentive to mills who wish to create new steels or steel coatings.

Maybe not so in the manufacturing processes but in steel products a patented steel product at least in automotive is not necessarily that great a thing. And that's what I found out in this product that we developed. Because we were quite excited about it and went out to the automotive industry and we're telling them about this...it was a win/win because it was a lower cost product to make but it had enhanced properties. So what better could you ask for. But the way the automotive industry works is they don't want a single source of supplier of any steel product because they want multiple suppliers of the product that they can feed-off against each other to lower the price. 'But if it's only one company that can supply it that's great but unless I have two people that I can put against each other to lower the cost I'm really not that interested in it.' So until our competition catch up with us on that particular product it's of really limited value. So it was an eye-opening experience for me. Now on the process side that's probably not true. If I have the ability to make steel for \$20.00 a ton cheaper then that is a huge advantage.

Steel Executive

In many instances, it is the responsibility of one or more staff members to keep up to speed with new technology, competitors' products, and marketplace influences. This can be a full time job or an informal side project, depending on the need for staying up to date. This need decreases in highly regimented sectors, such as lower tiered automotive part manufacturers or secondary steel manufacturers. In these instances, so long as the customer's needs remain the same, there is not a heightened need to be aware of external changes since it does not directly affect their line of business. This results in a relaxed, more informal information sharing method, where the president or a senior

manager responsible may check in with his or her contacts or favourite journals once in a while. However, in advanced manufacturing sectors, tier 1 automotive firms, or steel mills, the need to keep up to speed is crucial for maintaining business and increasing efficiency. These companies are more likely to employ staff members who oversee this information exchange as a formal part of their position. These people then turn to journals, organizations, and extended networks to better understand changes in product or circumstance.

Q: So you're going to your sales teams or your engineering teams to really understand what you think that the need is out there in the market.

A: Yes that's what we start with. We looked at some of the older best-sellers which were no longer in our product offering because we had focused on one volume item from us and we had to retain it at that plant for that particular customer only. So we looked at the historic information based on existing knowledge of the sales information and we brought that line back for a different industry.

Steel Executive

Q: This is sort of a bigger question but what is the most effective method of transferring knowledge and technology from universities to industry? Is there one particular way you think is best? Would it be like a consortia or formal meetings?

A: In our case it's informal; in our specific case and for a small company it's informal. For a large company, for a large organization or consortia it's a good way and I know that there are universities that do that. But we're too small to be involved as a major player because of time and because of the financial commitment.

Advanced Manufacturer

Innovation within the steel industry has been traditionally led by engineers. They are the dominant vector of technological change. A second recent report for TRRA looks at recent developments with the engineering labour market. What is observed is a 'thickening' of the engineering labour market. The boundaries and hierarchies between engineers, technologists and technicians are becoming more overlapping and blurring. Two of the relevant implications are: The total cost of R&D may be reduced as a result, to the advantage of local firms. And, increasingly technologists have taken over the lead role on the shop floor in process improvement engineering.

Interviews with steel producers suggest that for new hire Engineers, about 2/3 are in fact management trainees and perhaps 1/3 work in R&D and product innovation. Process improvement is largely done by community college trained technologists and technicians.

We agree on the thickening of Engineering labour markets. Technicians and Technologists from Community Colleges are more often used in the Process areas.

Steel Executive

Among other things, this suggests that the Colleges of Applied Arts and Technology (CAATs) have a critical function in future of controlling the production lines and process improvement innovation.

This is particularly important in the steel industry where process improvements in the metallurgy are so central to product improvement and innovation.

5.3 Cluster Economic Rents

As mentioned above, in the final analysis, cluster economics may be more important for appreciating the impact of steel on the Canadian economy than traditional macroeconomic multiplier impacts.

Recent academic work has drawn attention to the importance of 'relational rents' as a more important factor than relative export success in examining the impact of industrial clusters. Rents as defined by economists are levels above competitive market levels of profitability. In the cluster context, these are gains beyond that reflected in traditional trade statistics (Wixtead 2008). The classic case of relational rents in the academic literature is that of Toyota and its interaction with its suppliers. The network economics of the OEM-supplier agents generates significant rents that are then shared by the firms within the network.

Future research may examine the phenomenon of relational rents in the steel technology, material and manufacturing clusters as their most important economic impact.

These rents are but a reflection of the underlying reality that the industry in the future in order to be competitive will have to invest in product and process improvements, to add value to products and improve productivity. It will not be able to rely on access to other people's technology and will have to build partnerships with universities, colleges and public research centres.

5.4 Working with Customers and Suppliers

Steel Companies Partnering with Their Customers

Steel companies have built very active partnerships with their customers in recent years, particularly over new product development. These are close-in partnerships well before there is a final product to take to the market.

New Product Development Process

The generic new product development process can be summarized as follows and is standardized as a methodology by local facilities across global operations.

- New steel products generally have some enhanced feature when compared with existing products. Examples include improved surface quality, increased strength, improved ease of forming and improved corrosion resistance.
- The process employs the use of cross functional teams with representation from all functional areas which are involved with manufacturing, marketing and sale of the new product.
- The process employs a ‘Staged Gate’ process. In other words, the development is broken down into a series of steps or Stages with decision points or Gates between each step.
- In preparation for Gate meetings a Gate report is prepared. At the Gate Meeting a presentation is given to the Gatekeepers summarizing the report.
- Gatekeepers include local management representatives from all areas including manufacturing, commercial, financial, etc.
- Support by Gatekeepers is required to move the product along to the next Stage of development.
- Decision to promote a product to the next Stage of development is based on a predetermined set of criteria.
- Development of products in Canada is coordinated with other North American plants by a Product Strategy Board (PSB) which includes Canadian representation. The coordination of product development between plants is done in order to maximize efficiency and minimize duplication of effort.

A generic graphic of the new product development process is as follows:

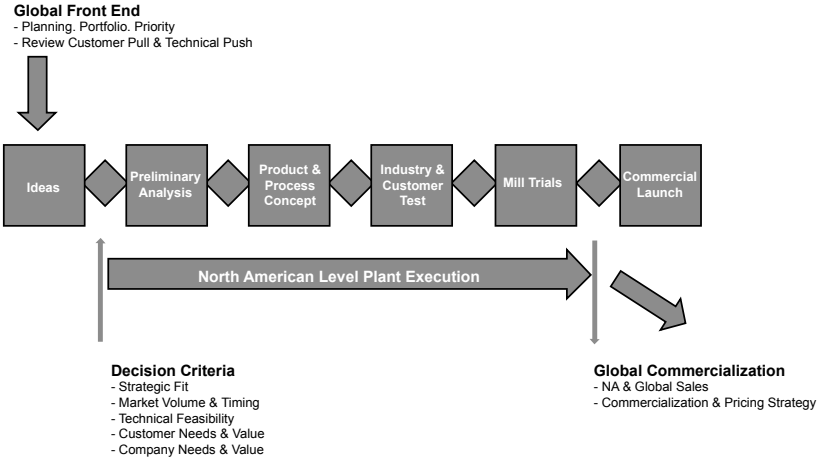

Within this procedure, some examples of Types of current Product Developments include the following:

Type of Steel Product	Product Enhancements
Automotive Advanced High Strength Steels (AHSS) Examples: Dual Phase, TRIP, Hot Stamped, Martensitic, Stretch Flangeable, etc.	Higher strength while maintaining formability Improved crash energy management Ability to reduce thickness/weight of parts
Pipeline Steels	Ability to meet strength requirements after heat treating in customers' facility Higher strength steels suitable for hydrogen sulphide environment
Tinplate Steels	Improved mechanical property uniformity Improved formability allowing for more flexible design Improved surface finish resulting in reduced tooling wear at customers' facility
New Steel Coatings	More environmentally friendly coatings Coatings providing improved corrosion performance

Steel companies also have gotten much more involved in the manufacturing processes and even cost management efforts of their customers.

An example is the appliances industry. The steel companies engage in a ‘teardown process.’ It is a technical approach to value creation for the customer. They systematically and rigorously disassemble the customer’s appliance product. They brainstorm on cost savings, evaluate the manufacturing process (stamping, fabrication, assembly, etc), design, material utilization and quality. In recent years this has resulted in tens of millions of dollars of savings that flow to the manufacturing customer.

The steel companies also engage in co-engineering support. Much of this involves the use of state of the art predictive tools to assist their customers in product development and improved material utilization.

Appliance Co-Engineer Activities

- State-of-the-art predictive tools assist customers with product development and improved material utilization.



Prediction of warping and twisting of enameled parts and assemblies



Prediction, optimization and testing of natural frequencies of assemblies (reduction of washer side panel vibration)



We all know about noises from our washing machines. The above graphic shows a simulation of noise patterns and the engineering pathway to reduce them in future.

In the automotive case, working with customers, from OEMs to Tier 1 suppliers includes: assisting them in the design of future parts using new grades of steel. Providing materials data to support their design requirements (formability, weldability, crash performance, fatigue strength, etc.) and obtaining Source Approval from the OEMs. The objective of the steel companies is to understand their future material needs in order to have the right new grades under development.

An example is the work a steel producer did with a customer and one of their Tier 1 suppliers for an automotive safety application.

The project was initiated in 2005. The objective was to develop a better roof rail to help meet new (tougher) vehicle rollover roof crush requirements while minimizing weight increase. It required extensive collaboration between them for over 3 years. It was implemented with the launch of the new model in September 2008. It involved the first production use of Dual Phase steel hydroformed tube in North America.

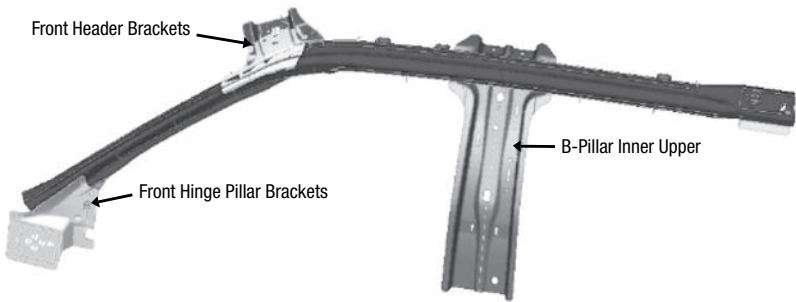

The challenge was that the Insurance Institute for Highway Safety (IIHS) new requirement for was for roof strength equal to 3 times the vehicle weight. Conventional design would have added 212 lbs to achieve equivalent structural performance. The new product was 75% stronger than the previous model. It was easier to manufacture. It was only 7% heavier (21 lbs.). It improved the Strength to Weight Ratio: from the 2006 design of 39.1 lb performance / lb weight, to 63.6 lb in the 2009 design.

For stamped auto parts, a good example is Dual Phase 980 steel. It is a new grade steel companies have developed that provides increased strength while maintaining formability. The increased strength results in improved crashworthiness without resorting to heavier thicknesses. It helps automakers achieve their structural and crash performance requirements while avoiding increased mass. The added formability helps the automaker to stamp complex shapes. It is a cost effective way to improve performance. Steel companies assist in the design of new automotive structural components by using CAE methods to simulate the stamping process and to recommend changes to the part geometry so that it can be stamped without splitting or wrinkling.

Auto Front Header

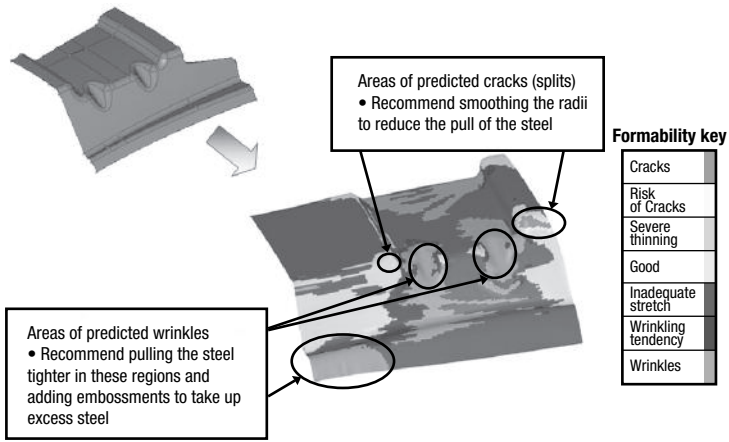

Steel companies also invest in high end computer hardware and software to perform predictive analysis for customers. This capability complements that of their automotive customers and that of private engineering design houses. They also provide full scale component testing facilities, used by their customers in their development activities.

Crash Simulation

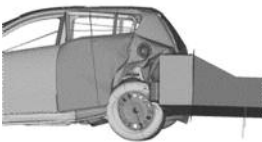

Stamping Simulation



Component Test



Another example comes from the Alberta oil and gas fields. In Northeastern Alberta a steel pipe producer works with a drilling customer to reduce drilling time and costs associated with mud removal while cementing in the drill hole. Proper cementing is critical in SAGD (Steam Assisted Gravity Drainage) wells so that proper zonal isolation and well integrity remains intact.

The drill holes are not simply vertical. Some are highly deviated, starting from vertical and building to 90 degrees inclination with legs of 10 to 14 degrees per 30 meters, making proper mud removal while cementing a challenge. There is a necessity for a high torque

connection that can withstand 25,000 ft-lbs for casing rotation during the cement job.

Looking for a connection that can endure both extreme temperature and pressure, the customer looked to the steel company for the best casing to run successfully in their wells. After testing various options, they developed a product with the highest torque rating of any connection and which has been tested at temperatures exceeding 360 degrees Celsius (the pressure of steam being injected). Due to its high torque capacity, casing rotation can be implemented in the well.

Intermediate Casing for Thermal Wells in Alberta

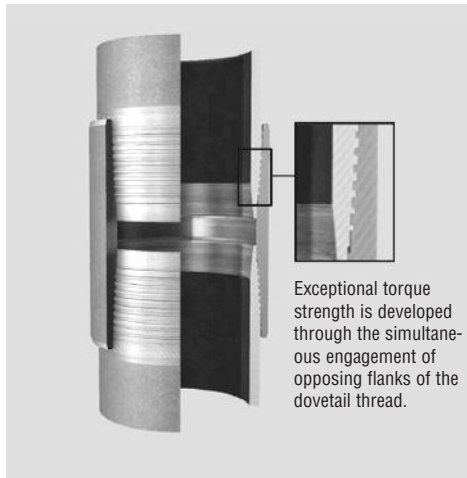

The new connection saves time and money. To date, the customer has run an average of 900 meters of pipe per well and they have drilled more than 400 wells using these products in thermal areas. Because of the high success rate of completing the casing runs the first time, the customer has saved additional rig time by avoiding tripping of the casing and hole cleaning operations.

The customer interface and new product development initiatives involve steel companies with numerous professional, social, health and environmental groups. An abbreviated, but representative list includes the following:

- Asthma Society of Canada
- Environmental Choice Program's Eco-Logo
- Green Building Council (CaGHB)

National Building and Construction Codes of Canada (NBCC)
Canadian Home Builders Association (CHBA)
Royal Architectural Institute of Canada (RAIC)
Ontario Architects Association (OAA)
Canadian Standards Association (CSA)
American Society of Testing Materials (ASTM)

Working With Suppliers

Suppliers are also involved in disseminating new technology. Because their goal is to sell new equipment to their customers, suppliers are always letting their customers know about the latest advances in technology. Many firms we spoke to rely on this dynamic to ensure that they are using the best equipment and materials available for their processes.

Customers, much like the sales teams of suppliers, are also in regular contact with direct competitors, especially when trying to find the lowest bidder or the best provider. In an effort to try to gain the best supplier, customers often share information as to how competitors' products, services, or price points compare to each other.

Q: What other people are offering, or what other companies are coming up with, do you look to that to sort of help to shape some of services you provide. Is it mainly customer driven? Is that how you provide your services?

A: It's mainly customer driven but we do look for services that we can offer and through the publications that we get. We also stay abreast of products that have been developed, refined and improved and we're on top of that and we provide those to our customers in our packages.

Q: Are you giving that information to your clients or do they sort of already know about it and they're looking for people who have solutions to things with new technologies?

A: Sometimes they don't know about it. Large companies, they're up on those things. We have smaller manufacturing companies that really depend on us for state of the art information, most efficient state of the art equipment for their particular process.

Steel Consultant

Conferences are important for marketing to customers but also for keeping up to date on what other competitors are doing, and what new markets they are targeting. Well established, specialized industries, such as the steel industry, are more reliant on trade

organizations for information. Organizations like the AIST often have their own political systems within, meaning that business contacts are often heavily linked to involvement in these organizations. The AIST has local chapters and meets regularly to discuss matters relating to the industry, including presentations by member companies on their newest product or service.

All of these stories reinforce the theme that to understand the interaction between steel companies and their critical manufacturing customers, one has to come to grips with the globalization of manufacturing and the importance of knowledge networks.

The issue arose in the interviews that as result of the changes in the companies, many of their customers have felt a distancing has taken place in their traditional relationship with the producers. Renewed and greater producer-customer interaction is vital to both sides, even more in the future than in the past.

6. Steel in the Knowledge Economy

Many people view the steel industry as the antithesis of the new knowledge-based economy. In reality, the knowledge and information based economy is alive and well in steel and has been for a long time.

6.1 The Japanese Steel Revolution

Henry Ford's assembly line revolution at the Highland Park plant in 1913-14 reduced the price of the Model T Ford from \$900 to \$300. It launched the era of 'Fordism' in industrial economies around the world.

Forty years later, the steel industry equivalent took place along Tokyo Bay with the Kawasaki Chiba steel mill in 1952. Kawasaki, notwithstanding the previous development and language of 'integrated' steel mills, built an entirely new kind of steel plant that was physically organized and internally coordinated in a revolutionary new way. The paradigm shift was reflected in the internal railway system. Where a typical world class mill had over 150 miles of rail lines, the Chiba plant has less than 60 miles. This fundamentally changed the flow of raw material inputs and steel processing. It meant a shift from batch production to continuous flow production that would lead to a new world of steel production and steel products. These were the metallurgy and production processes for the Japanese quality revolution in manufacturing that became evident for consumers a decade later.

The Chiba experiment in its first stage, began with the old furnace technology, the Open Hearth. These were later replaced by the newer BOFs. The difference in Chiba was in the overall layout and integration of the whole steelmaking and processing capacity. With this revised architecture of steel mills in hand, the revolution moved to the ‘hot end’ – the hot metal producing part of the mill. The basic steel making capacities of Japanese mills quickly became multiples of what their European or North American competitors were capable of. The revolution began with the new high capacity, large diameter, Blast Furnaces but it quickly spread to the rest of the steel mill.

The traditional steps, familiar to most people in old grainy videos sequences, were production of the raw steel, pouring or tapping the molten steel into huge buckets that were then moved by giant cranes to stations where they poured streams of hot metal into ingot moulds. The ingots were then stored until needed for rolling. The ingots were then re-heated in soaking pits and moved to rolling mills to be turned into plate or sheet products. The whole multi-stage process was costly and energy intensive. Achieving and maintaining quality was a constant challenge.

The continuous casting machine (CCM) became the means to simplify and more closely integrate many of these steel production steps. The product from the BOF would be poured directly into a mould that produced a constant stream of slabs which could then immediately be moved to the finishing stages for transformation into plate or sheet. The BOF-CCM configuration reduced direct costs by 30-50%, produced a continuous stream of product and opened new avenues for controlling and improving quality.

The new continuous steel production process, in addition to eliminating dozens of individual steps in the process, also unleashed such volumes of steel that the flow could not be dealt with by the former mechanical and human processes. The volume of steel throughput drove the next technology step which was the introduction of computers to the steel making and processing system. The first large scale introduction of computers in the steel industry for production purposes began in the late 1950s and early 1960s, again in Japan. Another steel innovation reference site emerged as the global benchmark, the NKK plant at Kimitsu, just around Tokyo Bay from Kawasaki Chiba.

The combination of computers with improved control systems now gave steelmakers the means and the data to continually monitor

metallurgical qualities of the steel making and finishing in real time. This was the second stage of the Japanese steel revolution. It went to the heart of the materials infrastructure underlying the quality revolution in the Japanese auto industry and ultimately in global manufacturing. We all now take this for granted.

6.2 Knowledge and Skills on the Shop Floor

The quality revolution in steel was not simply a matter of machines and metal. The human element and social organization soon came under the same challenges as traditional technical steelmaking. The traditional batch production steps of making steel in the Open Hearth, monitoring it and getting ready to tap it for the moulds, etc., had as its complement a very intricate hierarchy of skills, occupations and social statuses. The oversight at the face of the furnace was controlled by the Lead Hand, a highly skilled worker with a team of Second Helpers, Third Helpers, Labourers, etc., along with the inevitable Foreman. At regular intervals they would peer into the furnace and judging by the colour and texture of the flame, would decide on adding different fluxes and charge (limestone, scrap etc.) to try to achieve the desired type and quality of steel. They would then take samples of the molten steel and pass these to the laboratory. When the steel met the technical specifications it was ready for the next processing stage. The steel wouldn't be released until the engineers and the technicians in the lab judged it to be fit. This time honoured system of procedures and skills hierarchies was used around the world.

However, as the Japanese mills scaled up they found that this whole system of procedures and work organization simply couldn't keep up with the increased flow and pace of BOF steelmaking. New instrumentation and continuous monitoring, enhanced by computers, came to replace the whole social organization and skills hierarchies on the shop floor.

Production workers and the metal itself couldn't wait for the engineers, lab technicians, etc. Responsibility for production control and ultimately quality control started to pass from the engineers to shop floor workers. And, given the connection between quality and products, this development was soon seen as strategic for management and the company as a whole. As a result Kimitsu soon became the site for the development of work teams and quality circles in the steel industry.

Kimitsu was a tipping point. The information economy was emerging in steel mills in the 1960s and 1970s, twenty years before it became a common term for society as a whole.

6.3 The Steel Mill as Laboratory

As volumes increased and downstream technology developed, computerization and shop floor skills evolved and the Japanese steel industry became the reference point for best practices around the world. A whole new perspective developed about the steel mill and technical innovation. The approach that dominated the first 75 years of 20th century steelmaking – that technical innovation would take place in specialized industrial laboratories of the German model and then transferred to production facilities for implementation – was challenged. The production plant itself came to be seen as the site of, or at a minimum, a co-developer of new technologies.

None of the Japanese steel companies had ivory tower research laboratories or R&D sites. They all had their labs in close proximity to or literally inside their production plants. Interestingly, Dofasco always kept its lab in the plant, not at a separate site as Stelco did.

However, this changed perspective on steel innovation involved more than just labs and production plants. The success of the Postwar Japanese steel industry was not simply a function of individual engineers, managers and companies. At the next level there were trade associations, professional associations of engineers and overseeing it all, the hand of government – the Ministry of International Trade and Industry (MITI) saw themselves as active players in the whole industrial development. This had a major impact on the direction and pace of change.

History is full of ironies and paths not taken. The punch line for Canadians on the Japanese steel revolution is that the two pivotal technologies – the Basic Oxygen Furnace and Continuous Caster – were first introduced in Canada by Canadian steel companies, before the Japanese and decades before the US industry adopted them. Why in Japan did the new technologies have a transformative impact on the steel industry, whereas in Canada they had a limited, local effect? The benefits in Japan flowed to the whole industry while in Canada, the benefits flowed only to the individual companies.

At the individual company level, Dofasco led the way with a fundamental shift in culture and philosophy of the steel company as a

learning organization. It walked the talk. Beginning in the mid 1990s, Dofasco started to reserve 1% of its total rolling time to experimenting and learning about new and improved grades of steel. Indeed it turned its mill into a laboratory then communicated the results to its staff and customers.

Why the difference at the national level? The answer lies primarily in the different social systems of innovation. There are such things as national systems of innovation and they make a huge difference in the real world of the economy.

6.4 How Steel Companies Learn

For the steel industry, as for every other participant in the new economy, the ability to learn is the key to competitive success, now and in the future. The problem is not that traditional steel companies don't learn, or they learn only certain things and tend to learn only in certain ways.

How companies learn is closely related to how they are organized. Steel companies have lagged other industries in modernizing their organizational structures and cultures. In 1962, the great business historian Alfred Chandler observed that the steel industry was virtually alone in staying with the centralized, hierarchical form of organization when all other major industries by the 1940s had moved to some version of the multi-divisional corporation pioneered by GM and Dupont. The GM model not only allowed it to produce different cars for different market segments - Chevrolet, Pontiac, Oldsmobile, Cadillac - it also made for a more diversified and innovative company.

It was 50 years later that Stelco began to experiment with multi-divisional organization - separate operating companies for Hilton Works and Lake Erie Works. Meanwhile the world had moved on to matrix-style organizations that were much more flexible and emphasized cross-functional coordination and work teams.

Dofasco, by contrast, when it became a fully integrated steel company under Frank Sherman in the mid-1950s, consciously decided not to go the route of Stelco or US Steel and the established form of organizational development. Instead, it developed an early form of the matrix organization. The pioneers in this area were ITT in the US and Panasonic in Japan. Dofasco's success in innovation in the 1990s flowed in no small measure from this different trajectory of organizational development taken forty years earlier. It built around

an inclusive culture that was ultimately more important in the long run than whether or not it had a union.

Steel Engineers

Traditional steel companies only learned what their engineers learned and even this was within a strict internal hierarchy.

US Steel and Stelco both developed large, centralized research and development laboratories in the 1960s. These were very important indigenous centres of technical excellence. Stelco Engineering in its heyday was the technical leader for the whole Canadian steel industry, easily dwarfing the technical resources of Dofasco, Algoma, or any other producer. The Stelco coil box for instance was a major innovation in the industry, later adopted around the world. However, there were two flaws in this approach, which only became clear later.

First, the centralized R&D centres of the North American companies were ivory towers set apart from the daily operations of steel plants. The Japanese steel companies by contrast, integrated their R&D efforts with operations. Their model used the steel plant itself as the laboratory. As mentioned, Dofasco followed the Japanese model and has always kept its laboratory close to the plant.

Second, the culture of steel engineers has always been more self-contained than others. Studies of basic attitudes, communication patterns and social interaction of steel industry engineers compared to software engineers in Silicon Valley for example, show that they are much more likely to keep to themselves. The technical term is self-referential. The tremendous pace of innovation in Silicon Valley by contrast is much more characterized by wide social interaction and mobility among companies. Active and flexible social networks have become critical to success in the computer industry.

Learning on the Shop Floor

Learning on the shop floor in steel has also been beset with the same rigid hierarchy. Steel alone among the major industries has insisted that every one of its hundreds of thousands of jobs be organized in a single hierarchy of skills and knowledge under the Cooperative Wage Study (CWS) system. CWS is often seen as a union programme but it was created by a group of management consultants in the 1940s and ultimately installed in all of the Canadian steel companies, including Dofasco.

This has served to resolve wage inequalities but it has come at the price of locating all learning on the management side of the table. There is a built in bias against employee empowerment and involvement. The Japanese industry developed a much more flexible wage structure along with work teams and shop floor technology innovation. The wage structure and employee involvement provisions in Canadian steel labour contracts only started catching up with the Japanese industrial organizational innovations of the 1960s during the last decade. With the recent change in ownership these innovations are now in limbo.

6.5 Steel Knowledge Networks

The world of steel has changed. Indigenous technical development within individual steel companies has now become much less important than technology transfer, licensing and industry consortia. New steel knowledge networks have surpassed individual company labs.

As stated earlier, in the last twenty years, competitive advantage in the steel industry flows to those who learn the quickest and implement the fastest. Dofasco proved itself to be much more agile within these new networks. It was much more involved in consortia like the Ultra Light Steel Auto Body (ULSAB) and the Steel Auto Partnership (S/AP). Dofasco's major commercial success in hydro-forming for instance, did not come from anything it invented itself, but acquired through the network. It simply became much better at learning and innovating than its rivals.

1980s & 90s: Steel Trade, Steel Innovations

The majority of steels in a recently purchased automobile did not even exist 10 years ago. This stands in contrast to the public misperception that steel is an obsolete smokestack industry. On the contrary, as this Report argues, innovation and new steels are a constant in the new steel industry. As one steel executive has said publicly, "This is not your grandfather's steel industry."

Innovation in steel is a complex process. It is sometimes driven by steel producers and sometimes the steel companies are pulled by their customers. Other times it comes from outside third-party sources. Some examples of each of these innovation paths are outlined in the following examples.

Auto Steel

This is the classic case of Customer Pull innovation. The quality and manufacturing process revolution symbolized, but not exclusively restricted to Toyota-ism, was a revolution not only in production processes but also for material inputs. It was the Transplant Japanese auto companies locating in Ontario during the 1970s that force-fed steel innovation into the operations of Stelco and Dofasco.

The tipping point and the driver [for dual phase steel] were the Japanese Transplants. The Japanese mills had developed it. The auto companies insisted on it, forced it on the Canadian companies, otherwise they would have gone to foreign producers.

Ex-Stelco Executive

The steel companies built on these innovations but they were dragged into the game by the transplants. It is not clear that Canada would have had as innovative a modern steel industry in the 1980s and 1990s if it hadn't been for the Japanese auto companies. As a result, R&D expenditures in the last 20 years have been led by auto-related steels. This was the leading user market and that was where the best profit margins were found for integrated steel producers.

Manufacturing

In the coming years, producer-push innovation may provide an opportunity for steel producers to increase advanced manufacturing customers. Having put such tremendous resources into auto steels in the last decade, there may be major opportunities for applying the new metallurgical processes and products to non-auto manufacturing uses.

There are extremely poor technical capacities in manufacturing in terms of understanding and applying the new steels. The stampers let Toyota and the steel companies do all the work. Stampers just work on cost and yields from processing. There is no development. Their margins are so precarious.

Ex-Stelco Executive

The Obama administration is now advocating a rebuilding of manufacturing capacity as part of the post-Recession, green economy. Non-automotive application of auto steels could be a big contributor to this rejuvenated productivity and sustainability story.

Innovation – Construction steel

New applications of flat-rolled steel are a major emerging story of innovation in the development and application of new steels. In this case, it is third parties outside the steel industry that may be the key innovators. In the case of new coated and painted steels, it is the paint companies that are the lead innovators.

Construction is not like the auto side of things which always is talking about Grades, micro-structures, etc. In this case, it is the paint manufacturers who are the source of innovation. The paint suppliers push innovation at the steel producers, companies such as Valve Spar, PPG, Becker Coating.

The paint guys call on us more than do the steel mills. We get incentives to utilize their new products then we push the steel companies.

Manufacturing Executive

This story is currently being played out in Ontario. In manufacturing and construction, coatings are the key innovation. The steel producers supply the substrates.

Similarly, in the West there is an exciting Steel Manufacturing story emerging around welding technology being led by Alberta. Steel fabricators for the Oil Sands projects are to some degree playing a similar role as the Japanese auto companies in Ontario. It is innovation in welding technology blended with new metallurgy that is changing the key determinant – welding – in steel fabrication. Again, like paints in construction, it is welding in fabrication that is driving new steel applications from outside the traditional industry.

The Alberta case raises important research and policy issues at the national level. As stated elsewhere in the Report, the steel industry has a strong record of innovation in the past. It will have to be even more innovative in the future. There are important differences between countries in terms of their success and trajectories of technological change. As summarized in the Historical Appendix, introduction of the BOF in Canada and Japan at virtually the same time, had very different impacts on the steel industries of both countries.

Recent research on innovation has put even greater emphasis on regional systems of innovation. (Wolfe & Lucas 2005) These knowledge networks of firms, educational and research organizations in the regions may in fact be the prime site of collaborative innovation in the steel industry in the future.

7. The Steel Growth Story

Some observers are concerned the industry will be flat or decline in the coming decades. In considerable measure, this is based on one's view of the auto industry and whether auto leads a downtrend in manufacturing as a whole.

There will always be an industry for high end products like auto at the 12-13 million vehicle level. But auto demand and therefore manufacturing demand will fall in the future. The high end with ULSAB will always be there but what of the rest?

In the future North America will have 85-90 MTs of production and 130MTS of consumption. The leaders will be high end auto plus oil and gas pipelines

Steel Consultant

In the conventional view, Canada may do somewhat better depending on demand for steel related to energy projects (i.e. oil sands and pipelines).

Two factors might bend a flat/declining line for auto steel demand in a more optimistic direction. First there is room for the development of non-auto applications of modern auto steels into other areas of manufacturing. This could mean an increase of 5% in steel demand. The second factor and potentially the Big Surprise may be new uses of steel products in construction. On this basis, the market for flat-rolled steel could be at a tipping point and result in 20% growth over time, equal to auto.

Public policies could significantly facilitate the penetration of flat-rolled steels into residential construction and also other buildings and storage facilities. A more active building code and trades training policies would be critical. Optimists believe that the construction market for flat-rolled could be a major new growth opportunity beyond the existing market in rebar and beams and theoretically could result in a 20% market growth over time, equal to the current auto share.

Beyond automotive steels, there are many other forces that will build demand for steel, and thus the potential for Canadian steel mills. To begin, as the BRIC and other developing countries continue their long-term economic development, the world will require much more steel. Within established North American markets, demand growth for conventional uses will expand for several reasons. The recovery

from the “Great Recession” will see demand increase. The need to invest in new and upgraded physical infrastructure (e.g. bridges, highways, municipal utilities, electricity grids) requires steel. Conventional energy developments will continue to demand steel precuts, and manufacturing and steel executives talk effusively about the potential for steel to contribute to alternate energy developments, from wind to solar power.

7.1 NAFTA Steel Market

The last decade has witnessed major changes in markets for steel, particularly in the dynamics of the NAFTA steel market.²

Two indicators of this change were the proportion of steel shipments that are exported and the proportion of the ‘apparent domestic market’ that is supplied from domestic production. Figure No. 1 shows the long-term trajectory of both of these trends.

Figure No. 1

Primary Steel Industry: Domestic Producer Share of Apparent Domestic Demand and Export Share of Domestic Output, 1998-2006 (Tonnes)
(Industry Canada / Statistics Canada)

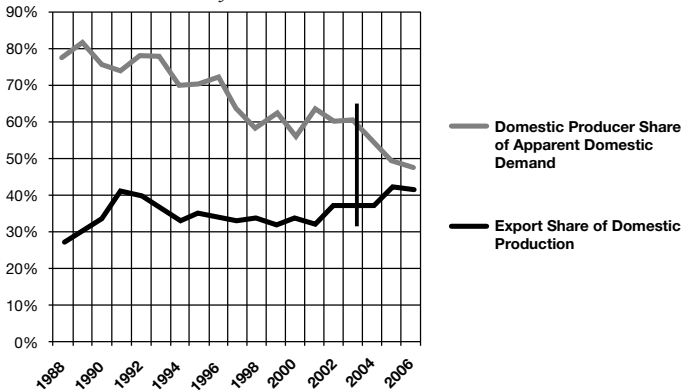

As can be seen from Figure No. 1, the domestic producer share of apparent domestic demand continued its long-term decline, while the share of domestic output that was exported continued to rise. These trends confirm that the Canadian industry is shifting to high value-added segments of the market while at the same time, the market for all types of steel – both low value-added and high value-added – is increasingly globalized. In 2003, 37% of output was exported. By

2. The following data was provided by Prism Economics of Toronto

2006, exports accounted for 42% of shipments. Over the next five years, this trend is likely to continue. Conversely, in 2003, domestic producers supplied 60% of Canada’s apparent domestic market. By 2006, this was down to 47%. Again, this is a trend that is likely to continue over the next five years.

Figure No. 2 shows that capacity utilization in primary metals manufacturing (NAICS 321) began to decline in the last quarter of 2008 as the North American economy weakened, but fell sharply in 2009. Indeed, capacity utilization rates in the third quarter of 2009 were the lowest since the current data series commenced.

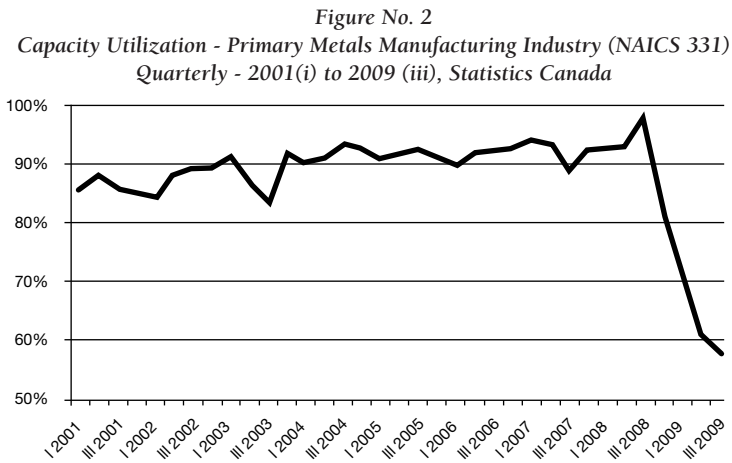

Figure No. 3 shows the decline in steel industry employment (NAICS 3311, 3312, and 3315), based on Statistics Canada’s Survey of Employment Payroll and Hours.³

Figures No. 2 and 3 indicate the following trends:

By 2004, human resources requirements in the steel industry had been reduced by around 20-25% in comparison with 2001. During this period, there was a moderate improvement in capacity utilization. The reductions in human resources requirements, therefore, were driven by business restructuring and the adoption of new technologies.

From 2004 to 2006, both employment and capacity utilization were essentially stable.

3. Statistics Canada’s CANSIM service did not release data on NAICS 4162 – Metal Service Centres

Figure No. 3
 Employment in the Steel Industry (Monthly)
 (NAICS 3311, 3312, and 3315, excl NAICS 4162)
 January 2001 to October 2009, Statistics Canada, SEPH

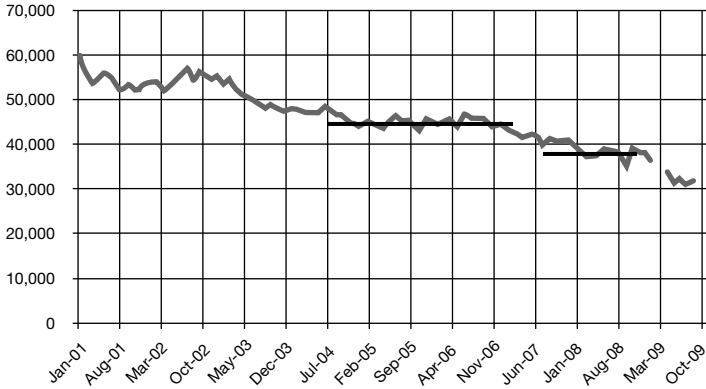

Towards the end of 2006 and into the first half of 2007, employment in the industry declined by around 15% which was linked to a decline in capacity utilization.

However, when utilization rates subsequently turned up, employment did not. This suggests that there were productivity-based adjustments to the higher dollar.

Towards the end of 2008, capacity utilization rates began a sharp decline. By the third quarter of 2009, capacity utilization was at the lowest since the data series commenced in 1987. This decline in capacity utilization reduced employment in the industry by a further 25%. Not surprisingly, the decline in capacity utilization was also accompanied by a decline in prices. Statistics Canada data show that industry prices have fallen by approximately 15-20% from their peak in the summer of 2008.⁴

Recent reports suggest the beginnings of a turnaround in the economic cycle, although the durability and strength of this turnaround is uncertain.⁵ However, the post-recession steel industry will not be a mirror image of the pre-recession industry. The scale and

4. Statistics Canada, CANSIM Table 329-0038

5. In June, US Steel announced that it would recall up to 800 workers to operate the Hamilton coke ovens. In January, Lakeside Steel announced that it had recalled all of its laid off employees and returned to employment levels last seen in November 2008. Arcelor Mittal Dofasco is also re-hiring.

severity of the economic downturn make that impossible. The downturn will accelerate changes in human resources that are already evident in industry data and also drive further changes in human resources that the data do not yet reflect.

7.2 Auto Steels

The leading R&D effort in the Canadian steel industry during the last 20 years has gone into developing new and improved steels for the auto industry. These High Strength Steels (HSS) have made a major contribution to making lighter, more fuel efficient and safer cars. The steel industry sponsored a major consortium to design the next generation sedan through the Ultra Light Steel Auto Body (ULSAB) project bringing together 34 leading steel and auto companies. This was also the steel industry's challenge to penetration by other materials like aluminum into the prime, profitable market niche for integrated steel producers, particularly for high end coated steels.

The ULSAB project, now a decade old, has had important impacts on the application of new lightweight, high strength steels into automotive manufacturing and more holistic design approaches. It also encouraged the spread of collateral steel manufacturing technologies like hydro-forming and tailor welded blanks.

However the world has moved on and has gotten more complicated, as global supply chains and technologies of steel customers have become a moving target. The product market leader in the 1990s was coated, Cold Rolled steel. Now, the use of Cold Rolled has lost market share to light gauge (and better surface) Hot Rolled and also Galvanized products. There has been a decline in Electro-Galvanized, especially in North America. Most coated applications now are either Hot Dipped Galvanized or Galvanneal. The upper end of Hot Rolled steel and processing have eaten into the lower tiers of Cold Rolled steels, once the holy grail of auto steel profitability.

On a global scale, changing dynamics within auto platforms have changed the specification and tooling dimensions of auto steels. For instance, the ULSAB was entirely devoted to HSS steels. However, the Europeans such as BMW and Mercedes have design platforms built around different advanced steels, Dual Phase, Complex Phase and so-called TRIP and TWIP steels. These are detailed technical but important differences from the standpoint of steel production and manufacturability. So, for a North American-based Tier 1 auto parts manufacturer, the growing market is non-North American OEMs with

Euronorm or Asian steel grade requirements, but the Canadian steel producers don't produce those grades and the presented 'alternatives' don't necessarily comply with the performance standards of the platform OEM designs. The suppliers are faced with the choice of not being able to meet their customers' requirements or re-locating to Europe where the appropriate steels are available.

The new customer base for Suppliers are the Europeans. These platforms have steels directly specified, they are embedded from the design to the tooling. North Americans brought into HSLA steels through the ULSAB. In the EU they emphasized structural grades of steel carbon content.

The European car platforms have European grades embedded in them. They are not offered here and the 'alternative' doesn't really meet the spec for the platform.

The weight in the cars is in the structural parts. This is where the advances in high strength steels may be most important. Either the steel will be produced here or the plant moves to Europe.

Tier 1 Supplier

Further, there is no pilot capacity within Canadian steel mills to allow the Tier 1 suppliers to experiment with multiple new recipes for new auto applications and a reluctance to provide small quantities to test out tooling options, etc.

There is not the capacity here to properly pilot the new steels from Design to Pre-Production to Product. We need to produce lots of Recipes. For instance in the tool set for the frame, 80% of the formability is in the first hit. You can't just drop in steels without addressing design and tooling from the start. HSLA requires forming over time in a series of steps.

We think Canmet going to Hamilton is a big deal and we will participate. It has pilot plant capacity, something that Canada and the steel companies don't have.

Tier 1 Supplier

This may be a gap where public policy and public research infrastructure could facilitate many future opportunities for further developments of auto steels.

7.3 Energy: Alternative and Conventional

Manufacturing and steel executives talk effusively about the potential for steel to contribute to alternate energy developments, from wind to solar power.

The wind towers are basically a play on plate steel, so we look to plate producers. We buy slabs and supply those to our Tier 1 supplier. There is an opportunity to get into the lower end of the supply chain and take advantage of the feed in tariff.

Wind power is a big interest for our company in Canada and around the world. Internationally, we know of countries where already the total steel consumption for alternative energy and the environment exceed that of the auto industry ... The incentives in Ontario plus the local content requirements make this a large opportunity for ourselves and our steel partners.

Manufacturing Executive

There is also an opportunity in this market to look at applications of new auto steels in other areas of manufacturing.

We are interested in learning more about new steels. The next stage of wind towers is in excess of 100 meters. Among other things, it raises questions about whether these sorts of towers can be physically transported to locations from the point of production using the existing infrastructure. This may drive us toward either lighter, stronger steels or other materials like cement.

Manufacturing Executive

There is also a conventional energy story concerning oil and gas, pipelines and hydro transmission. The biggest story is Alberta and its steel industry.

Next to Hamilton then Edmonton is the most steel intensive local economy because of the Oil Sands. It is built around machining and fabrication shops supporting oil and gas. The availability of turnings – scrap metal from machining – feeds back as an input for our EAF furnace.

Oil sands projects and Upgraders are primarily a manufacturing business. Maintenance and upkeep is huge.

Steel Executive

Alberta steel companies see themselves as an intricate part of the emerging manufacturing industry in the Province.

The local Manufacturing cluster has been active with the Alberta government and the University of Alberta in research and development around metal working and welding. Welding costs in Alberta run into the billions of dollars.

Welding technology is a big issue - steel weldability. It is the primary methodology for using steel in the Alberta economy. Productivity issues are directly linked to it.

Steel Executive

Steel manufacturing is seen as a critical player in the future of the province and of the country.

Our message is a sustainable manufacturing base needs a value chain analysis. You have to look at a refinery and upgrading value stream – fabricating business, fitting, assembly etc. It is critical to keep a base of operations in manufacturing (including refineries and upgrading) servicing them has created innovation and we export it around the world.

Steel Executive

After the Oil Sands, the next biggest future challenge for steel producers will be the capacity or lack of capacity to deal with the planned Alaska Pipeline should that materialize. It is a huge opportunity but also a constraint.

The challenge is in development of new steel technology with the properties of high strength for tubular steel in high pressure situations, acidity conditions, cold temperature and welding capabilities. In some cases, we can make the steel in Canada but not roll it here.

Steel Executive

Given the tonnages involved in pipelines, steel companies have a strong incentive to develop new approaches for making and selling these kinds of steel from scratch.

We are pushing into new product markets in pipelines. There is a different pipe product in the international market place, with value added for weather conditions.

Steel Executive

Our energy future is complex and so are the opportunities for the steel industry to contribute.

7.4 Construction: The Big Surprise?

Construction may be the Big Surprise for the future of the Canadian steel industry. Steel has always been an essential product in construction in products like rebar for reinforced cement and beams, girders etc for major industrial, commercial and institutional structures. However we may be on the verge of a new opportunity of a different kind.

Most academic study and commentary on steel in the last decade or so has focused on the auto industry and auto steels. Given its historical, strategic impact this is not surprising. However, construction may become a critical but subsidiary market for the Next Steel industry in the coming decade.

In 2008, the auto industry accounted for 14-15MTs of steel consumption in North America. The construction industry accounted for 20MTs.

Traditionally, construction steels were used in large items such as beams and girders, as well as smaller products such as rebar. These are still important markets and various Canadian producers supply steel products for such purposes. In the past, Stelco put a major effort into penetrating the residential construction market but pulled back after failing to meet its objectives.

However the future story will be the application of flat-rolled, sheet steel in construction for things like roofing and panels. For roofs, steel can displace asphalt for economic and environmental reasons. It can also be used in the shells of buildings and for energy generating applications of voltaic coated steels.

Stelco engineers made a major developmental push for steel framing. It was tied to Residential construction but it didn't take off. The Trades weren't into it. They expected it to overtake auto but it never did. Now other Construction exceeds auto but it is more on the ICI side. It is exteriors the 'skin' or building envelope.

The 'cool roof' is a big innovation story in the US. It utilizes reflectivity and only one steel producer can do it. Asphalt roofs are used across ICI (Industrial ,Commercial and Institutional) and it is a terrible material. It should be replaced with steel. It is much better environmentally and in terms of energy usage.

Ex-Stelco Executive

For those now trying to take advantage of the opportunity, the new construction steels could represent high value opportunities as much as auto steels, which will remain intensely competitive.

The story is not grade development, it is painting and coating. Lead times are also an issue. It requires changes to the steel business model. In construction I get an order on Monday that needs to be filled on Wednesday. In auto it is really 30-40 days but lots of inventory is stored at the parts producers etc. There is inventory stored all over the chain. Not so in construction. It requires different interaction and logistics.

Manufacturing Executive

The thought that there might be higher margins in the future for construction steels than auto steels is a completely counter-intuitive idea for most steel managers.

Materials Competition in Auto and Construction

How steel performs in the New Economy in the future very much turns on how well it competes with other materials, partially for energy and environmental reasons. Its future is also dependent in part on where it is placed in the merging of materials and manufacturing.

Everyone knows steel vs. aluminum and the huge resources in people, R&D and marketing and PR have gone into it. ULSAB was its poster child. If a similar effort was made in construction in contending with cement, brick etc., then it would have a big payoff for steel volume. If steel penetrates construction in these ways it has a much greater impact on volumes than further work in auto.

The cement and wood guys are around lobbying on the Codes all the time. A new steel product requires new codes and specs, all different. However it is not tougher than trying to get all the different car companies to agree on the use of new steel for a strategic frame part or something.

Ex-Stelco Executive

The competition between materials is well illustrated by the contrasting auto and construction steel cases.

For the past 30 years, there has been intense competition between steel, plastic and aluminum for their respective places in the future of the automobile. Projections of future aluminum or plastic body cars have been more the stuff of science fiction than what you can observe on parking or car sales lots. The steel industry has mounted a vigorous forward looking technology development vision around the Ultra Light Steel Auto Body (ULSAB) consortium. The steel case is that the new steels are lighter and stronger, with better surface qualities and much better energy efficiency and re-cycling records than either aluminum or plastic. This is a true and an under-appreciated story.

It is also the case that there is 85 years experience with the steel unibody in automotive assembly, tooling and skills, from assembly workers to auto engineers, all embedded in manufacturing. The competing materials have huge learning and retooling challenges to overcome if they are to ever be really competitive with auto steels.

Fundamentally, the material competition in auto is around the respective metallurgy properties of the product.

It is a very different but equally interesting story in the new construction steels. Here steel competes against wood, concrete, asphalt, etc. The competitive barriers and challenges in construction

are less issues of metallurgy than other factors external to steel or to manufacturing. If the new steels are to really penetrate and take off in construction then they have to confront the barriers that are embedded in building codes, construction regulations and building trades’ certification and training.

The challenges to new steels in construction are not metallurgy. They are regulatory reform and human resource policies. This is a very difficult and different challenge than in automotive. However, if quantitative growth in North American steel demand in the future critically depends on construction, then this will have to find a place in the public policy agenda of the industry.

8. Steel Trade Issues

8.1 Global Economic Crisis

As a result of the global economic crisis, NAFTA steel production declines in mid-2009 were larger than those in other regions of the world.

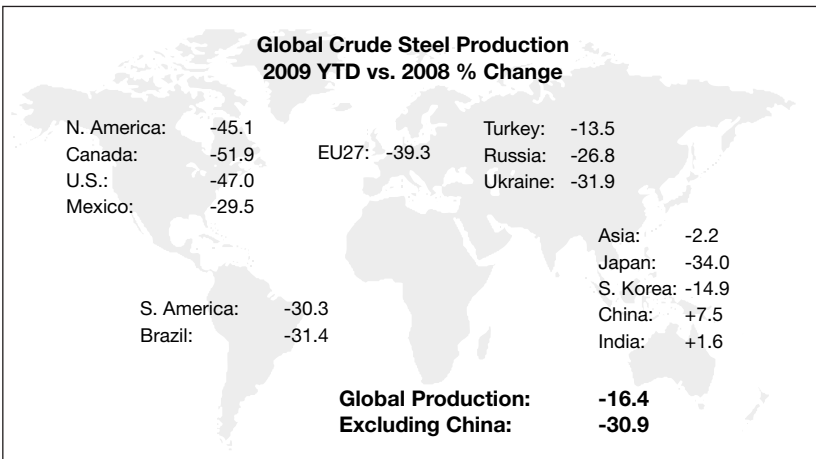

As a result, the NAFTA Steel Trade Balance with the rest of the world (ROW) going forward is in a fundamentally different situation. The steel balance in the region has shifted from one where it was historically steel short (requiring imports), to one where it now has the capacity to increase production for domestic and export consumption, without the need for net imports. Given the anticipated post-crisis steel consumption growth in NAFTA and ROW, this is a significant opportunity for NAFTA steel producers.

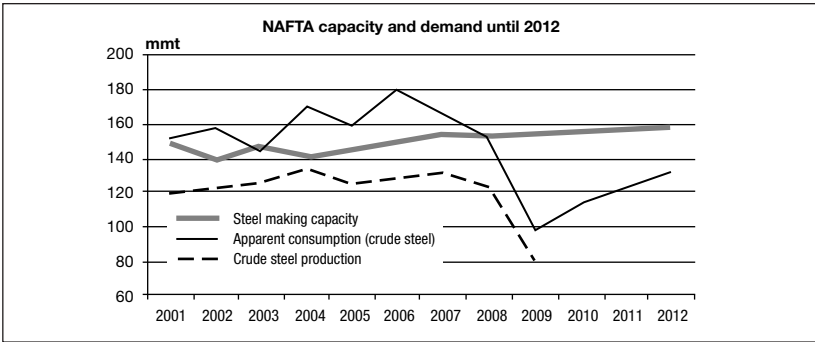

8.2 Impact of China

There is an obvious challenge for producers and policy makers over China’s potential to directly upset this opportunity through non-market behaviors. In addition, there is the problem of indirect trade in steel because of China’s presence in manufacturing and displacement of NAFTA manufacturing capacity.

China now represents almost half of global steel production. In the last 10 years, it has increased its crude steel production by over 400MTs, and increased its share of world production from 15% to almost 50%. On average, over the last 10 years, China has added twice the size of the Canadian steel industry every year.

China’s Crude Steel Production

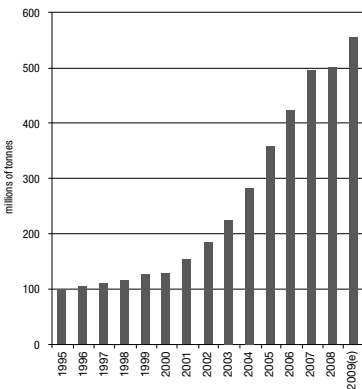

China’s Share of World Production

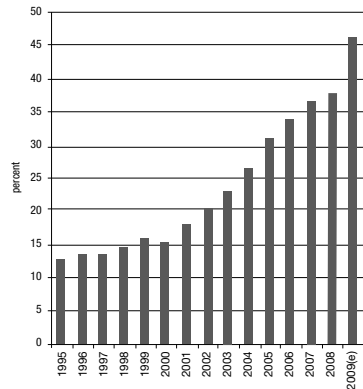

Source: World Steel Dynamics, Inside Track #77 (May 30, 2007); World Steel Dynamics, Truth & Consequences #44 (Nov. 15, 2007); World Steel Dynamics, Inside Track #87 (June 12, 2008); World Steel Dynamics, Truth & Consequences #50 (Feb. 9, 2009); World Steel Dynamics, Inside Track #97 (Oct. 2, 2009).

The best source of data and forecasts for global steel come from the OECD Steel Committee in Paris. Their most recent Steel Outlook, is from December 2009.

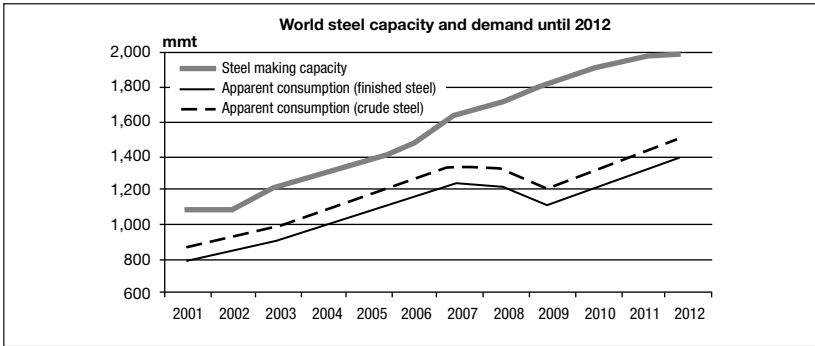

The OECD sees world trade as recovering over the next three years, led by the major non-OECD countries of the BRIC (Brazil Russia, India, China). Their projections suggest that world steelmaking capacity will rise from 1,806 million tonnes in 2009 to 1,986 million tonnes in 2012. World steel demand is expected to rebound in 2010, and grow by 6-7% per annum in 2011-2012 to reach a level near 1,500 million tonnes by the end of the period.

While there is uncertainty surrounding the outlook, it appears that amount by which world capacity exceeds demand, which averaged approximately 216 million tonnes during 2000-2007, will widen to over 500MTs. Such an overhang presents significant structural challenges to the industry. It raises questions about how the industry adjusts and what government policies might be to help manage the situation.

In the critical case of China, the OECD observes that capacity growth outstripped demand growth from 2002-07 and it turned into a large exporter of steel in the latter part of that time period. By 2012, based on the OECD forecast, China will still have an excess of capacity in the range of 150MTs, or approximately 10 times the size of the entire Canadian steel industry.

Global steel companies are unanimous in the view that China's steel industry is firmly embedded in a powerful state-business nexus. Chinese steel enterprises are not operating in a competitive domestic market environment, but rather uphold very close relations to government agencies on local, provincial as well as central levels.

Except for two enterprises, their top 20 steel corporations are state-owned on a majority basis. China is a non-market economy in steel.

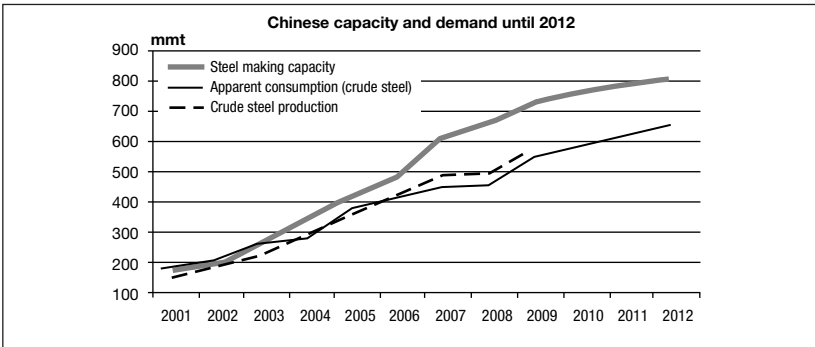

In China’s steel industry, a multi-layered system of politico-business alliances can be summarized in the following schematic:

The State-Business Nexus in China’s Steel industry

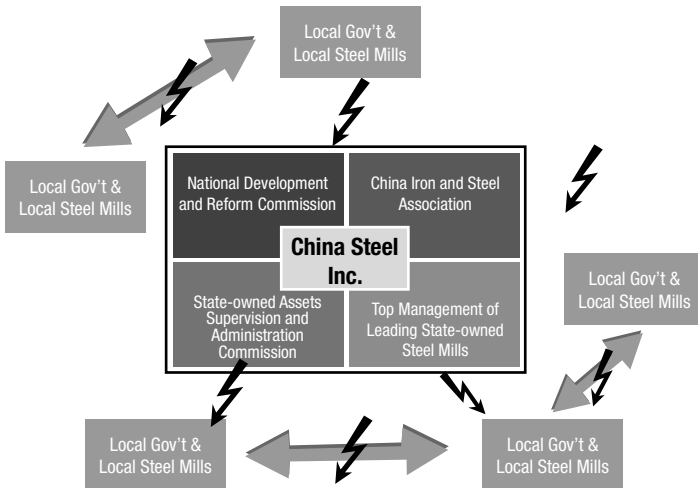

Source: Report prepared by THINK!DESK China Research & Consulting for EUROFER – the European Confederation of Iron and Steel Industries. January 2009

Chinese governments support ‘their’ steel enterprises through a National Steel Policy and provincial/local actions. The broad array of mechanisms includes currency/capital market interventions, direct and indirect ownership, subsidies, quotas, import/export taxes/rebates,

export targets, etc. Government intervention is provided across the entire supply chain, including energy, raw materials, steel, manufactured products, etc. The interventions are structured to artificially and selectively increase the competitiveness of Chinese goods, while concurrently increasing costs and decreasing relative competitiveness of other global players. China is no longer just a supplier of lower added-value steel products; instead, it has shifted to export more higher value-added materials encouraged by government

Fundamentally, China lacks natural advantages for steelmaking relative to NAFTA. China must import significant amounts of quality raw materials, at world prices, which represents the majority of their total production costs. Growth of coal fired plants, limited supply of steel scrap, and less efficient and environmentally challenged mills reduces their competitive balance. Their cheap labour does not offset their real cost disadvantage, as steelmaking generally requires less than 2 hours of labour per tonne.

As a result, Chinese steel exports to NAFTA actually incur higher costs than those that arise for NAFTA producers supplying the local markets. Netting out subsidies and the impact of government market interventions would prove that the real ‘market-based’ cost structure of Chinese steel production to be substantially higher than officially reported.

Comparative Steel Production Costs: China vs EU

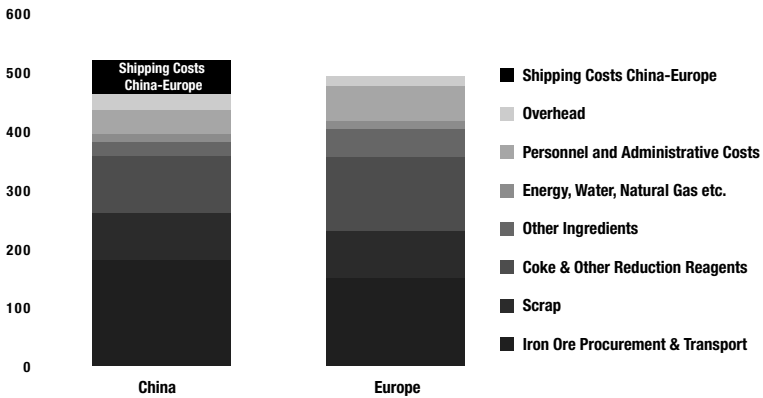

Source: Report prepared by THINK!DESK China Research & Consulting for EUROFER – the European Confederation of Iron and Steel Industries. January 2009

“If we could get some change in China’s currency policy, it would help the world”

Paul Krugman, Businessweek March 12, 2010

Nobel Prize-winning economist Paul Krugman has recently said that global economic growth would be about 1.5 percentage points higher if China stopped restraining the value of its currency and running trade surpluses. He says that China's currency policy has a 'depressing effect' on economic growth in the U.S., Europe and Japan, as measured by gross domestic product. If China's currency, the yuan, were not undervalued, it would have a 'significant' impact on the global recovery.

China also has a significant impact on manufacturing trade deficits and indirect steel trade deficits (steel embedded in other Chinese imports).

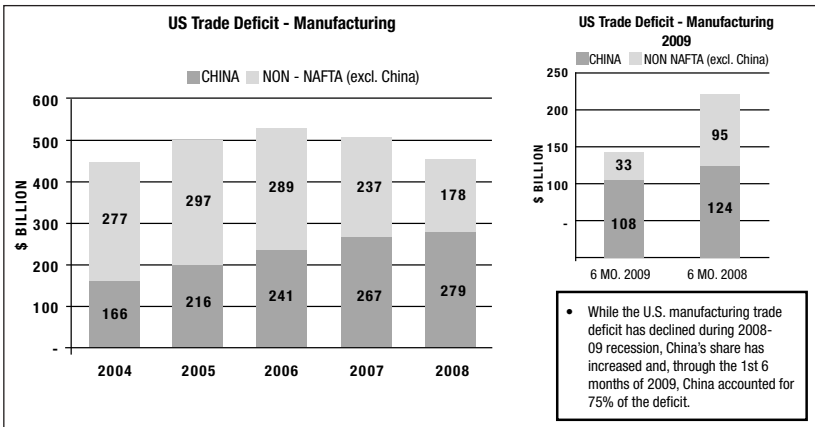

For steel in particular, the indirect steel deficit trade remains a major source of concern.

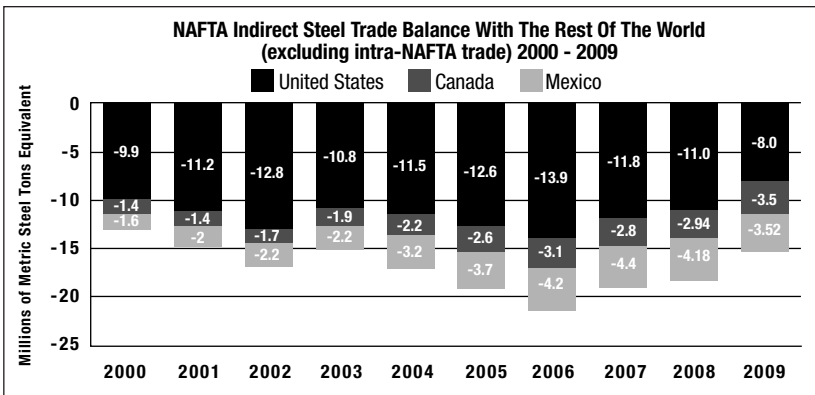

8.3 Key Trade Flow Drivers

Certain structural features of the steel industry can have a significant influence on trade flows.

Steel making is capital intensive and involves relatively high fixed costs. Consequently, there is an incentive for producers with significant excess capacity to increase production to spread fixed costs over a greater volume of production.

However, there is a countervailing incentive to align production with demand in a steel maker's domestic market. Excess supply in the 'home market' can result in pricing instability which can negatively impact returns.

The NAFTA steel market has become the home market for steelmakers in Canada, the United States and Mexico. However, global excess capacity and the emergence of China and other countries as major steel exporters has introduced significant challenges for steel makers in the NAFTA region.

The combined effect of global overcapacity and the incentive to maintain high production levels creates an incentive for steel makers located in markets with significant excess capacity to increase production for export markets. This allows steel makers to act in a manner that promotes pricing stability in the home market while increasing capacity utilization by selling into export markets.

This situation may be further exacerbated in situations where governments adopt policies that influence production decisions and/or confer production or export subsidies on steel products.

The combination of overcapacity and government involvement has resulted in widespread dumping and subsidization of steel products on export markets. For example, the first table in the next section lists the measures currently in force in Canada, the United States and Mexico arising from the dumping and/or subsidization of Chinese steel products in these countries.

8.4 Steel Trade Disputes

Over the past decade China has emerged as a major driver of international trade disputes. For example, since joining the World Trade Organization ("WTO") in 2001, Chinese government measures affecting a wide variety of industries have been challenged before the WTO. Other WTO members have brought challenges against

measures affecting auto parts, financial services, intellectual property, taxation and technology products.

Duties Imposed on Chinese Steel Products

Product	Canada		United States ⁶		Mexico ⁷	
	Dumped	Subsidized	Dumped	Subsidized	Dumped	Subsidized
Hot-rolled sheet	X		X			
Plate	X		X		X	
OCTG	X	X				
Seamless OCTG	X	X				
Standard pipe	X	X	X	X		
Carbon steel butt-weld pipe fittings			X			
Drill pipe			X	X		
Steel concrete reinforcing bar			X			
Steel nails			X		X	
Light-walled rectangular pipe and tube			X	X		
Steel wire garment hangers			X			
Circular welded carbon quality steel line pipe			X	X		
Circular welded austenitic stainless pressure pipe			X	X		
Steel threaded rod			X			
Welded steel chains					X	
Welded carbon steel pipe					X	
Seamless Steel Pipe					X	
Steel bolts					X	
Steel valves					X	

The lengthy list of Chinese steel products found to have been dumped and/or subsidized in Canada and other export markets illustrates that

6. United States International Trade Commission, "Antidumping and Countervailing Duty Orders in Place as of February 19, 2010, by Date of Order" (Washington, D.C.: USITC, 2010), online: <[http://info.usitc.gov/oinv/sunset.nsf/0a915ada53e192cd8525661a0073de7d/96daf5a6c0c5290985256a0a004dee7d/\\$FILE/orders%20February%2019%202010.xls](http://info.usitc.gov/oinv/sunset.nsf/0a915ada53e192cd8525661a0073de7d/96daf5a6c0c5290985256a0a004dee7d/$FILE/orders%20February%2019%202010.xls)>, accessed 29 March 2010>.
7. Mexico Ministry of the Economy, International Trade Practices Unit, "Sistema de Información sobre las Prácticas Comerciales Internacionales" (Mexico City: Ministry of the Economy, 2010), online: <<http://www.pymes.gob.mx/upci/>>, accessed 29 March 2010.

the structural features of the steel industry combined with government influence and support have resulted a pattern of dumping and subsidization in export markets.

Most recently, the United States, Mexico and the European Community have initiated WTO dispute settlement proceedings regarding the Chinese government’s system of export restraints affecting raw materials (Canada is an active 3rd party participant to the proceedings). It is alleged that China maintains a system that restrains exports of raw material inputs used in the production of finished goods such as steel. The export restraints are alleged to raise world prices while lowering Chinese domestic prices for key steel making inputs such as coke.⁸

Market Forces Restoration

Unfair trade practices are often the result of asymmetric market access and economic distortions in the exporter’s home market. Dumping and subsidization cause negative economic and consequences on affected communities.

The existence of non-market influences and government support of the Chinese steel industry serve to increase Chinese exports and cause distortions in the importing country market. The economic consequences of dumping or subsidization from the importing country’s perspective are illustrated in the following graph.

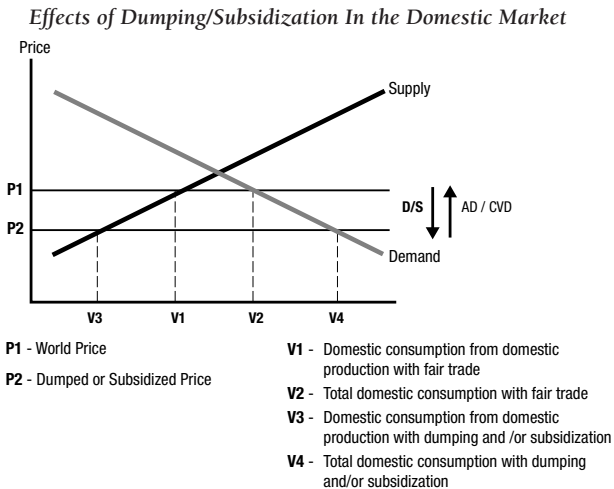

8. China- Measures Related to the Exportation of Various Raw Materials, WT/DS394/7.

Government support and other structural factors allow exporters to lower their selling price from the world price (P1) to the dumped and/or subsidized price (P2). The impact on domestic producers in the importing country is decreased volumes sold in the home market (domestic share drops from V1 to V3). Exports at unfairly traded prices experience a corresponding increase (V2 to V4).

Unfair trade laws minimize the disruptive economic and social effects that unfairly priced imports have on established communities by restoring market equilibrium.⁹ The imposition of anti-dumping and/or countervailing duties on dumped or subsidized exports restore production to undistorted levels by offsetting the effects of the dumping and/or subsidization.

8.5 Trade Liberalization

The negotiation of trade agreements involves the balancing of concessions and opportunities by the parties to the agreement. In principle, each agreement should be assessed to determine whether, as a result of a given agreement, Canada would be better off with it than without it.

The existence of effective trade remedy laws contributes to trade liberalization by providing a mechanism to address specific concerns about the potential negative effects of unfair trade, while allowing for broader trade liberalization.

From a trade policy perspective, trade liberalizing agreements should increase the overall size of the market available to Canadian producers. This involves an assessment of the access granted to the Canadian market in exchange for improved or expanded access for Canadian producers in export markets. Providing trading partners with expanded opportunities in the Canadian market is one half of the equation. The net benefit of a given agreement can only be understood by examining whether the increased access offered to the Canadian market also affords Canadian producers with an equivalent or greater opportunity in export markets.

As noted above, the NAFTA market has shifted to a steel long situation, which means that producers in Canada and the other

9. See for example, Alan Sykes, "The Economics of Injury in Anti-Dumping and Countervailing Duty Cases," (1996) *International Review of Law and Economics*, Vol 16, Issue 1, pp 5-26.

NAFTA countries have the ability to serve the needs of the NAFTA market as well as export markets. Consistent with Canada's Global Commerce Strategy, this dynamic should be taken into consideration during the negotiation of future trade agreements.

The view of the industry is that to maintain a steel balance in the NAFTA region, there must be a public policy commitment to restore North American manufacturing as a foundation for economic growth and sustainable employment. They view China as in effect pursuing a mercantilist policy in violation of the content and spirit of the international trade rule regime. Furthermore, they warn about the risk that inequitable application of climate change policies will allow those with little to no regulatory burdens to in effect, in the future engage in environmental steel dumping. The latter would both be trade-distorting and also prejudice the environmental and sustainable development objectives that the NAFTA steel producers themselves endorse.

9. Steel, The Environment and Recycling

Technical experts in steel believe that over the next decade the determinative variable in future technology trends within the steel industry will come from outside. They will be driven by environmental and energy policies. Although the Canadian steel industry has more than met the much disputed Kyoto GHG goals, the pressure will continue for all industry to become more energy efficient, and emit lower levels of GHGs. This is a pressure that has both global and domestic implications, as witnessed by the recent U.N. proceedings in Copenhagen.

The steel industry has identified energy efficiency and climate change as a major challenge for more than two decades. Long before the findings of the Intergovernmental Panel on Climate Change (IPCC) 2007, major steel producers recognized that solutions were needed to tackle CO₂ emissions. They have been highly proactive in reducing energy use and greenhouse gas emissions and while continuous improvements are always being sought, steel producers in Canada are now operating close to the lower limits of currently available and commercially applicable control technologies.

Even the best steel mills are limited by the laws of thermodynamics in how much they can still improve their energy efficiency. For integrated producers in particular, over half of the CO₂ emissions are essentially fixed in the chemical and thermal processes for making steel. With

most major energy savings already achieved, further large reductions in CO₂ emissions are not possible using present technologies. The kind of further reductions being called for by governments and international bodies requires the invention and implementation of radical new production technologies. A set of breakthrough technologies is needed; the kind of paradigm shift in industrial production that can change the way steelmakers around the world operate.

Various research programmes have already identified more than 100 new technologies, and classified them in terms of the CO₂ reduction they could achieve. Some technologies are ready to use but would deliver only a small reduction in CO₂ emissions. The more ambitious projects in terms of CO₂ reduction are now going through various steps of scaling up from lab to commercial reality.

The coal-based ironmaking technologies associated with carbon capture are among the most likely candidates for early viability. Hydrogen and electrolysis are further into the future, as these technologies will require deeper re-engineering of steel production and the development of new processes from first principles. Biomass solutions are probably in the intermediate future. In the even longer term, new avenues of research are likely to emerge. These include the integration of steelmaking with solar power generation, with new energy technologies and with new, fourth or even fifth generation nuclear power plants. Such solutions are not yet part of the ongoing development programme, but could be added in the future.

Nonetheless, the focal point for the next decade will be environmental policy and regulation. At the core is the basic steel producing furnace technology.

GHGs are the Big Story that will lead the development of steel technology over the next decade. The EU is in the lead. There are two choices. Either you can adapt the Blast Furnace, which is further along the road right now. Or, replace the Blast Furnace but this is a longer story.

Sequestration of CO₂, putting it under ground is a major American focus. The US Energy Department supports it. The Lake Erie Works of US Steel has the right kind of limestone deposit to store it, in theory. But putting it in the ground may only be a partial and temporary solution.

A paradigm shift in technology will look in a different direction. But, the record for new iron making processes is not good. There are three candidates in the European initiative. They don't reduce CO₂ very much.

Steel Consultant

Electric Arc Furnaces (EAFs) have an inherent advantage among steel producing facilities because they have a smaller carbon footprint. They use at least 30% less carbon to produce a ton of steel (excluding issues of the electricity grid), and perhaps even less, due to their reliance on recycled steel as the primary feedstock. However the story gets complicated. There is concern that they may just shift the burden to the electricity provider.

EAFs have a CO2 advantage, but they may just shift the burden to the electricity provider and further on down the food chain.

Steel Consultant

International experts in the industry don't see a fundamental breakthrough in steel's carbon footprint any time soon.

We don't see a breakthrough near term. There may be improvements on energy efficiency or synergies between companies that improve net CO2 results. The combination of better raw materials with new technology can go a long way on better CO2 results.

Otherwise you are smelting bad stuff.

Steel Consultant

There may be improvements on energy efficiency or synergies between companies that improve net CO2 results, but this is at existing facilities. Greater improvements in ironmaking may be possible but would require green field sites.. Co-generation as done in some mines currently could also marginally contribute and Canada could have an expertise advantage here. More could be done at green fields but there is no movement likely in this direction from the companies or the public in the near term.

9.1 Steel Recycling Story

The steel industry has also made enormous strides in reducing particulates and effluent discharges in the last twenty years. All steel mills for instance try to minimize discharges and recycle their water. Steel making uses a lot of water. Some mills have achieved zero discharge; they recycle every drop of water.

The strongest stories come from the EAF mills.

We are the biggest recycling story in the world and in Canada. Steel is the most recycled product around.

Steel Executive

Beyond the general claim for steel, which is true in comparison to other industrial materials like aluminum and plastic, there is the record of steel producers operations themselves and how they have changed in recent years.

We were the first steel company to have all operations registered to ISO 14001 environmental standards. It shows up in performance. There were always concerns about cooling water and effluent from steel mills. We have no discharge from our mill. We weren't on a waterway so we had to figure out how to minimize water usage. We now have a zero effluent water system. Not even from the washrooms.

Steel Executive

The achievements in steel have literally been remarkable from one end of the ecological story to the other! More importantly, the steel companies have not only cleaned up their own operations but contributed to the clean up and environmental standards for the society and economy as a whole.

We have a scrap company and developed material acceptable criteria for PCBs, mercury switches since 2001 - ahead of all the other steel companies. The Methodology we used was then adopted by Environment Canada and the EPA.

Steel Executive

However the job still is not entirely done and much remains to be done, some of it controversial. The record of the steel industry is undeniable. The conversation is not over.

9.2 Steel Scrap

The steel scrap story requires further elaboration, both because EAF steel producers account for approximately half for North American steel production but also because the steel scrap story is an important economic narrative in its own right. It also gives another perspective on how steel contributes to the economy in new and different ways.

The EAFs have a strong green story to tell. They use a lot less energy than BOF mills (30%) and generate a lot less GHGs (10%). Some 98% of their material is recycled.

Steel mills, particularly EAF producers often have their own scrap divisions or subsidiary companies. The mills use low grade feedstock for commodity products like rebar. They use recycled auto and appliance material for higher grade products.

High grade product is available as waste from auto and other manufacturing plants. Shredding comes 60-70% from cars being recycled. Appliances are next and the Loose Material (LOC) is the remainder.

Scrap operations do a Value Chain analysis of the scrap supply chain. Some material also comes from old buildings and this recovered steel can be endlessly recycled into construction applications. Re-cycled steel from cars is more limited.

We shred 20,000 cars per month. One per minute. The cars are crushed.

We take about 400 tons per month from the municipalities, drawing from 70 municipalities.

Railcars are another source. We have recently contracted to source 3000 rail cars from a financial services company.

Steel Executive

They also work with dealers and pull product from municipal dump sites. About 10-15% of the feed comes from municipal dump sites. The latter would be made much easier if preliminary sorting were done by consumers through Blue Box sorting.

In fact some municipalities are starting to re-mine their dump sites to extract metallics. In municipal dumps, the steel is easily separated because it is magnetic and can be drawn out. Everything else must be hand sorted. Small motors for instance are 88% recyclable. The rest is copper.

Steel Executive

Contamination issues are critical to the inputs. From the stand point of the industry, if there were no Canadian steel mills, the material would still have value and be transferred somewhere in the world.

Ontario has always been in a scrap surplus but with the downturn in automotive, it may become in a scrap deficit situation. An EAF steel mill for instance is in Oshawa because they are close to auto and other manufacturing scrap sources. If they have to import scrap then other countries may not be operating with the same environmental obligations.

In Japan you can incinerate medical waste but not here.

Local police also bring fire arms once a month to be put into the feedstock stream. Drugs and weapons also are put in.

We have the potential to recapture all sort of steel goods for recycling e.g. bicycles, rims, etc.

Steel Executive

Lower priced feedstock can also come from tires. In other countries, they recover the steel but also burn the rubber to get carbon. Canadian GHG rules restrict this, although there are plants in the US recycling the complete tire. In other cases, they are incinerating tires in the cement industry in Quebec.

The EU has the most complete recycling programme and rules. The life cycle perspective should be a guide for policy for the future across the industrial materials sector.

9.3 Energy: Counter-Intuitive and Ontario Power Authority (OPA)

There is another, somewhat counter-intuitive story of steel in the emerging economy stemming from the industry's established profile as a leading industrial electricity energy consumer. It is an Ontario example but numerous jurisdictions are experimenting with so-called feed in tariffs in their electricity grids.

For many steel companies, their energy costs exceed their labour costs. They could potentially reduce their energy costs by 25%. If this was done on the labour side of the equation, it would be a banner headline. The Ontario Power Authority (OPA) is interested in steel and other big industrial customers because of the demand and efficiency response.

OPA wants to purchase steel customers' ability to manage load, by time and consumption levels. This is not easy to understand at first. Energy consumption should be seen and managed as an asset which can produce revenues. Time shifting and reduction produce the revenues. There is a 1:1 conversion.

Steel companies have to think about innovating with their suppliers in new ways. They should think of their consumption from the power grid as an asset from which they can derive new revenues and not simply as a cost to be managed.

Electricity Supplier

This model of managing is more easily implemented by EAF producers because they can more easily time shift and scale their production process than BOF producers. For the former, efficiency is more easily managed. The BOF producers have a large load but going to off peak periods presents a bigger challenge.

If they are customers under contract, the potential gains from this programme are more than from co-generation projects.

There is a tension between these programmes and lean production objectives. It works best where there are medium storage points which lean production objectives seek to eliminate.

The OPA want to fund energy management improvement. Producing new management tools is the goal. Their fundamental economic objective is to reduce and avoid the funding of new nuclear reactors.

These are emerging but intriguing economic and policy developments that we would not even have thought of only a couple of years ago.

10. A Sustainable Steel Industry for the Future

It is the central objective of this Report to examine the changes and opportunities of the Canadian steel industry and indicate directions in which public policy may support and assist it in taking advantage of future opportunities.

10.1 Conventional Policy Issues

When you ask steel company executives about public policy issues, they list a conventional programme of reduced taxes, constrained electricity rates, effective actions on dumped imports and concerns about the pace of environmental regulation.

A number of public policy issues have been emerging throughout this Report.

The Europeans have a very elaborate European Steel Technology Platform that they are developing and have every intention to implement, to guarantee a place for the industry in the future of their economy.

The Obama Administration has now published its new Framework for American Manufacturing. Steel has a prominent place in the emerging US policy framework.

What does Canada have? Very little that is new and forward looking to be frank.

There are in fact many complications involving policies and jurisdictions.

The Federal government has clear, traditional roles in international trade and commerce, taxation and areas of environmental regulation. It also exerts significant influence, including regulations and funding, in areas such as transportation, infrastructure, and skills including immigration policies. Continual interests by the industry in these policy areas are legitimate.

At the same time, the new opportunities in alternate energy applications of steel and the critical opportunities in construction very much correlate with provincial jurisdictions in Building Codes, trades training and certification. The provinces are also major players in environmental regulation, and in industry-critical areas such as education and training.

To the extent that the steel industry mounts an ambitious future oriented policy agenda, it will increasingly be oriented to policy interventions with sub-national levels of government and public policy development.

As stated above, the EU has the extremely ambitious European Steel Technology Platform. The Americans have steel as a major feature of their new Framework for American Manufacturing. The industry and governments in Canada need to roll up their sleeves and develop and match strides with our trading partners.

10.2 New Policy Issues

Lewis Mumford described iron as the material substrate of the emergent urban Industrial life style of the 19th century. The most obvious transformation was in the new revolution in transportation of rails, so famously captured in JMW Turner's painting *Steam, Rail and Speed* portraying a locomotive speeding across a bridge through the English country side and capturing the power and thrust of the Industrial Revolution.

The Modern life style of the 20th century was built on and of steel. In Canada it was the railways, steel ships bringing the new Canadians to our shores and steel skyscrapers to our cities. Ironically the skyscraper emerged as an architectural solution when some brainy steel engineers turned the design of a steel railway bridge on end to enable them to build taller buildings. They took the idea from Chicago to Manhattan and the rest is history.

We are now all actively engaged in the early stages of debating the directions and implications of a new Post Industrial economy and society; this time at a global level.

Some of the components are already clear:

- Light, fuel efficient cars
- Recycling
- New and renewed energy sources

- Urban design
- New and renewed infrastructure.

For all of these, steel is a critical component.

10.3 A Horizon of Supportive Public Policy

Steel will be a central part of the materials infrastructure of our future sustainable economy and society. The design and production of the materials we need is only limited by our imagination and dialogue about the environment, life style and economy we want for ourselves and our children. The materials will be there to match the vision.

In the OECD's scenario for steel the main issues for public policy will include:

Environmental legislation: achieving effective environmental legislation based on consensus among all players and creating a level playing field so companies can base their decisions on appropriate economic factors.

Labour market policy: elaboration of labour market policies ensuring appropriate support for steel workers, particularly policies for those who might lose their jobs.

Competition policy: to prevent mergers from restricting competition in critical steel product segments as well as access to steel raw materials.

Preservation of markets: to enhance and strengthen existing trade rules to avoid market restrictions and trade frictions resulting from policies in other domains such as environmental regulations.

The OECD Report concludes by pointing out that the future importance of steel industries in all countries will be determined by others' capacity to engage in an effective and inclusive dialogue with other parties in society. The OECD perspective and list of issues provides a useful script for the start of those discussions.

Policies to support the steel industry and manufacturing are inherently linked. The recent Roadmap for Recovery by the Canadian Manufacturers and Exporters (CME) provides a good summary of policy prescriptions in support of manufacturing.

- i. To develop a more concerted strategy for innovation, manufacturing, and international business development
- ii. To encourage investment in productive assets

- iii. To encourage innovation, the adoption of new technologies, and the commercialization of new products and technologies
- iv. To improve the ability of businesses to develop and take advantage of international opportunities
- v. To improve the quality and availability of workforce skills
- vi. To improve access to financing for competitive, creditworthy businesses
- vii. To strengthen Canada's energy and logistics infrastructure
- viii. To improve regulatory efficiency

Source: Roadmap to Recovery: Charting a Course for Economic Renewal, Canadian Manufacturers and Exporters, Ottawa: March 2010

10.4 Policies for Steel

The extent to which Canada's steel industry will grow for the future begins with the companies themselves – their investments in their people, in capital and innovation, and strategic decisions about product and market development. The industry must continue to innovate on a broad basis to sustain its competitiveness, especially given the upward exchange pressure on the Canadian dollar and the ever-growing competition from imports.

It is evident, however, that all of these decisions and factors are influenced in virtually every dimension by government actions as well – in the form of policies, programs, and regulations. Thus, when one considers the importance and scope of public policy for the steel sector, it is less about targeted actions that are steel-specific, and more about the bundle of policies that contribute to strong industrial performance.

It is beyond the scope of this Study to develop a national policy framework for steel, let alone the increasing part of that agenda in provincial and even local jurisdictions. That said, the research points to several areas where supportive public policy will advance the competitive conditions for Canada's steel future.

First is to recognize that the 'new economy' includes steel. As discussed, steel can indeed be considered an early mover in the knowledge-based economy. The industry is not a 20th century relic; it is in fact essential to many of the innovations that will drive the economy in the future, e.g. conventional and new sources of energy,

including shale gas; more fuel efficient automobiles; enhanced environmental performance; and, more environmentally efficient construction on a lifestyle basis.

The second point is about the competitive environment. Most obviously, this is about competing in domestic and export markets, and ensuring a fair basis for Canadian producers to do so, through trade rules and their enforcement. It will remain important to continue to challenge distortions caused by foreign subsidies and other non-market forces such as product dumping into Canada.

More generally, it is critical to recognize that the steel industry is now truly global. The industry transformation that resulted in the steel industry becoming part of global multinational enterprises means that Canada's mills must compete for investment capital in that context. From a public policy viewpoint, this means that Canada must offer competitive conditions to attract future investment and re-investment.

Several dimensions of public policy are evident:

- a) Fiscal/monetary/social – The overarching importance of our fiscal situation particularly as compared with others and monetary policies while not allowing destructive short-term swings in the Canadian dollar. Canada should not engage in a race to the bottom, but realistically industry will need tax incentives that will favour Canada as an investment destination, and market-based currency movements. On this latter point, the extensive subsidization inherent in China's exchange rate management is having a direct impact on steel producers and their customers in developed economies such as Canada.
- b) Productivity, Innovation and Skills – Given the rapid rise of the exchange rate against the U.S. dollar and most other relevant currencies including China, Canadian industry must continue to invest in its people, its industrial processes, and technology. Public policies can play an important role through tax-based or program measures directed at the development of the highly-skilled workforce; investment tax measures to enable capital stock improvements, and R&D tax credits or support to develop the technologies needed for the short and longer terms. This includes R&D policies for transformative technologies that will redefine the environmental footprint of steelmaking globally as well as in Canada.

- c) International Trade – As governments seek to further the benefits of increased two-way trade, and as they seek to create greater market access for Canadian producers, the inevitable ‘balancing act’ of trade agreements will have a direct effect. From a steel perspective, new trade negotiations, such as FTAs with major and emerging economies must provide genuine market access for Canadian value-added industries. Second, as is amply demonstrated by the sections of this paper on trade, including China’s steel policies, the maintenance and enforcement of strong trade rules internationally (i.e. the WTO) and domestically (e.g. the Special Import Measures Act) work to ensure the competitive functioning of the domestic marketplace in Canada, enabling Canadian producers to compete on a fair basis in their home market.
- d) Canada-U.S. – Given the highly-integrated nature of the North American market for steel, improving intra-NAFTA efficiency is important to steel customers and to the industry. Government action can help in areas such as the efficiency of the Canada-U.S. land border crossings, the competitiveness of the Great Lakes shipping system, and further progress as contemplated by the recent Canada-U.S. agreement on bilateral government procurement access.
- e) Infrastructure and Logistics – Road and railway networks are the physical underpinning of the goods economy, especially for products like steel and its material inputs. Extending and rebuilding existing systems goes beyond short-term recovery spending, with the additional benefit of creating new demand for steel products that Canada produces competitively, e.g. rebar, plate, steel pipes and tubes. Rail and road transportation regulations are an important additional dimension to assure competitive logistics within Canada, and to export markets
- f) Environment – Looking to the future, it will be important that new environmental regulations or policies result in balanced environmental policies from several perspectives. First, incremental costs of environmental regulations that are not similarly borne by producers in competitor countries, whether that be the US or China, will disadvantage Canadian operations. Second, environmental policies in Canada are a shared federal and provincial responsibility. Regulatory harmonization is

essential to avoid inconsistent regulations and the attendant costs to producers. Third, an important ingredient of environmental policy must be the development of new technologies.

- g) Energy – Energy has two broad dimensions for steel producers. As an input factor, energy is a major cost element, thus placing a premium on policies that will assure the availability and competitive cost of needed energy sources. Particularly as governments seek to reduce CO₂-intense sources of supply, they will need to ensure appropriate replacement sources are available for industry. New sources of energy, both conventional and non-conventional, also offer a major industrial opportunity for steel producers, e.g. new pipelines, hydro plants, nuclear power, windmills, and attendant transmission systems. One part of the new energy sources “equation” is the need to streamline project approval processes to advance both environmental and economic interests in a timely manner.

This is not a complete nor detailed policy ‘Agenda’ for the Canadian steel industry. It is presented here simply to identify some key areas of public policy that will impact the future of the steel industry, and of the broader manufacturing sector. A sound, balanced mix of policy will strengthen the competitive conditions for steelmaking in Canada, so that Canada will continue to benefit from steel’s potential as an innovative, competitive industry in the 21st century economy.

Appendix 1: A Short History of Canadian Steel

A Short History of Canadian Steel

The steel industry has been vital to the Canadian national identity. The great Canadian scholar and public intellectual Harold Innis grounded Canadian economic history, political and cultural development in our economic geography with his landmark works; *The History of the Canadian Pacific Railroad* (1920) and *The Fur Trade* (1922). The so-called Laurentian Thesis was the defining reference point for much of the 20th century for Canadian scholars, students and communications theorists. It also resonated in our literature and art.

Innis argued for the essential cogency of Canada i.e. we are not a political accident making a goal line stand against assimilation by the United States. The source of Innis' insight into the nature and implications of our economic geography was an earlier book by another McMaster University scholar William Donald, *The Canadian Iron and Steel industry* (1915). Donald argued that the steel industry was not just the creation of Sir John A. Macdonald's National Policy alone, but was grounded in our geography, communities and natural resources.

The steel industry makes sense, as Canada makes sense.

The National Policy Steel Industry

Iron, as Lewis Mumford had said, was the universal material of the late 19th century. It stood for all that was good and rich and strong and modern. Sleep was sounder in an iron bedstead, learning more solid on a school desk anchored on cast iron grills. Streets were better lit by ornate iron gas lamp standards. Iron rail and iron engines and iron railway stations were an invitation to the pleasures of speed and a new kind of adventure.

The business centre of the Canadian steel industry was originally in Montreal. The management of the Montreal Rolling Mills had come from within the industry, mostly up from the shop floor. The presidency and Board were dominated by Montreal banking and merchant capital with political connections. An astute management had been able to expand operations steadily and to follow the advance of technology more readily than its local competitors, two of which it eventually purchased. Good location, adequate supplies of labour and raw materials, tariff protection and a growing domestic market had all been prerequisites essential to success. However the future lay with

linking the two processes of iron-making with steel-rolling, particularly with the new technology of open-hearth furnaces.

The next stage of the industry's evolution would be played out in Hamilton.

The rise of the modern iron and steel industry in Ontario was closely tied to public policies regarding railways and trade. The Ontario Rolling Mill Company in Hamilton was started by a group of Cleveland investors to take advantage of the new 1879 tariffs protecting Canadian manufacturers. The Yale-educated young secretary of the company, Charles Wilcox, would become the first President of the Steel Company of Canada. The mill the Americans acquired and re-opened had belonged to the Great Western Railroad, predecessor of Canadian National. Hamilton serviced a total of five railways because it was placed squarely on the two continental axes running from Montreal up the St. Lawrence to the West and from New York up the Hudson-Mohawk Valley to Chicago. One of its enduring advantages was the market created by the repair and manufacturing shops of the Great Western Railway. The largest in Canada at the time, they supplied locomotives, cars, rails and equipment. They would later become part of National Steel Car. Hamilton was not in the midst of an iron or coal field but by rail and water it was closer to both resources than most industrial centres.

Rails became the first major item to undergo the shift from iron to steel when the large-scale manufacture of cheap steel was made possible in the 1870s following introduction of the Bessemer process, a British invention that was largely commercialized in the United States. It was a process of making steel by blowing air through molten pig iron and thus oxidizing the carbon, manganese, silicon and phosphorous.

The movement from iron to steel in Canada took place under the ever present danger that US producers would simply move in and dominate the Canadian market. In 1909 US Steel bought land near Windsor Ontario with the apparent intention of building a completely integrated Canadian steel manufacturing centre. This was one of the motives behind the organizers of the merger creating Stelco. When Max Aitken was putting together the acquisition of the Montreal Rolling Mills, eventually to be part of the Stelco merger, he was approached by both US Steel and Jones & Laughlin to take over the Montreal company. US Steel had already acquired the Dominion Wire

Manufacturing Company in Lachine. After a rebuff from Aitken and the Stelco consolidation, they sold their interest.

Dominion Steel of Nova Scotia (Dosco) was still the dominant producer in the Canadian primary industry. It produced almost 40% of the iron and steel made in Canada. Stelco, on the other hand, was now heavily loaded with finishing capacity – over one-half of the country's business in most hardware lines – while it accounted for only about 10% of the country's steel production.

In 1910, although still a small steel business by American standards, Stelco was one of the most complex and varied horizontal mergers yet made in the steel-finishing industry anywhere in the world. It was also advanced in vertical integration of the steps in the steelmaking process. As such, it was well along the road to technological progress and efficiency in the early 20th century steel industry.

Just how formidable the problem of competing with the American rolling mills was can be appreciated by a comparison of the relative size of the Canadian and American markets for steel. Frank McKune, a Stelco superintendent pointed out to a House of Commons committee in 1910 that an average order for an American firm would allow them to run for 2-3 days without changing rolls. But a Canadian order was unusually large if it made possible even one full day's work without stopping for a change over. Canadian customers required the same variety of products but in much smaller quantities.

To meet the heavy American competition and to capture a larger share of the Canadian market, the management of Stelco was determined to proceed as quickly as possible with a major building programme. By 1913 it had the world's second electrically powered blooming mill, and a combination rod and bar mill, also electrically powered, which was the first of its type to be installed in North America.

Other steel companies had major challenges and disappointments in managing growth. The two Nova Scotia companies, Dosco and Trenton, were reorganized into the British Empire Steel Corporation after the war. The exceptional growth period of 1915-20 had led them into a serious error of judgment and they suffered severely in the 1921 crash. By 1921 Stelco was the equal in size and significance to the combined total of what had been the two previous giants of primary iron and steel in 1910, Algoma and Dosco.

The automobile age set the pace for the post-WWI steel industry. The auto makers required special chemical properties for their steel and exacted new physical specifications in elasticity, tensile strength and hardness. The demand for sheet steel rose spectacularly. Metallurgists were driven to discover steel so treated that it would roll flat and thin and then twist into a radical curve without cracking. With these new steels manufacturers of stoves, washing machines, refrigerators etc could discard wood and cast iron as the chief raw material in home appliances. They also presented a problem of smooth surfaces which steel makers had not paid attention to before. The problem of producing miles of wide-sheet steel and cold rolling it was solved by Armco Steel in Ohio. The world's first continuous wide-strip sheet mill was only made possible by the immense but precisely controlled motive power of electricity.

The cost of building such a mill in Canada was so huge that the entire Canadian market would not have supported one such facility. Stelco had to be content for the next twenty years with adapting and improving its own reversing sheet mills. Even then, public policy assistance was required to offset some of the disadvantages of scale in the Canadian market, in the form of accelerated depreciation on equipment. This was critical for introducing the new technology in the late 1940s.

The fast growing new industries of the interwar years tended to concentrate in an industrial belt along the upper St. Lawrence and lower Great Lakes. Electrical equipment manufacturing which rose spectacularly to become the country's third largest industry by 1929 was located throughout this area. The big new mining and non-ferrous metal industries of Northern Ontario drew their supplies largely from the same industrial belt. Stelco's plants were within a few miles, and in some cases within a few hundred yards, of the majority of their steel using customers. Besides the advantages of lower freight rates, the opportunities for selling and servicing through frequent personal contact and rapid delivery were in Stelco's favour.

From the very beginning, Stelco had dominated the steel finishing industry in Canada. It was known as the Woolworth's of North American steel and it probably manufactured as wide a variety of products as any other steel company in the world. But it became now, for the first time, the largest producer of steel ingots in Canada. However, the most expensive modern machinery was not always considered by management to be within the company's reach.

C.D. Howe's Steel Industry

The next major shift in the industry came during and after WWII. It is not an exaggeration to call the modern, postwar steel industry C. D. Howe's Steel Industry.

Prior to WWII, government involvement in steel was comprised of continual adjustments to tariffs, bonuses, freight rate adjustments, tax exemptions and government guaranteed orders such as for rails and relief work. The steel companies themselves set prices, established product lines and made technology choices as they saw fit. All this changed with the War. Government now imposed its directions and decisions in all these areas. However it did so with an incredibly close consensus between the government and industry leaders over wartime needs and directions, notwithstanding tensions between strong personalities such as C. D. Howe and Sir James Dunn of Algoma Steel.

Algoma's own priorities for the war period were expanding capacities in a wide range of semi-finished steel which would find broad application among postwar consumers. Algoma was the most closely involved with Ottawa. Of all the wartime government grants and subsidies to the steel industry for capacity building, about 80% went to Algoma.

At the heart of the government process was the Steel Controller, H.D. Skully, reporting directly to C.D. Howe. Advising the government were the Steel Advisory Committee of business and government officials, the Scrap, Iron and Steel Advisory and Technical Committees, plus several dozen seconded dollar-a-year men.

Steel Control applied its regulatory and administrative interventions to the point of production rather than consumption. Among other things, Control produced a Steel Budget of physical production requirements for each year. It sought to expand production in areas of shortage through capital assistance and special tax concessions.

Howe and Dunn both saw the challenges in the steel industry being solved in a continental context. Howe believed that Canadian steel should build up a well-rounded basic capacity, and specialize only in those areas for which there was sufficient domestic demand to warrant efficient and profitable production. The rest should be imported from the States. Both men saw Canada moving towards a mutual dependency with the American steel industry. Any further expansion should avoid serious imbalances for the postwar period. So, for

instance, the 1941 Steel Budget projected requirements as 3,390,000 tons, with 1,140,000 furnished through imports.

Wartime steel demand was driven by two dynamics. The first was obviously the need for munitions and war materiel, all of which required steel. At the same time, steel was a necessity for construction of the factories and machinery required for munitions production. 1941-2 were the most challenging years for matching both needs, while munitions alone predominated from 1943 to 1945.

In direct capital expenditure, Ottawa assumed the cost of plant additions, vested title with the contractor, and bound him to a low-cost production contract for the duration of the war. Special depreciation allowances were very broadly used to accelerate private investment, whereby companies could amortize new capital expenditures at accelerated rates and advantageously redistribute their taxable income.

Dunn got off the mark early with Howe in pointing out Algoma's fundamental imbalance between its 700,000 tons of raw steel production capacity and its mere 450,000 of rolling capacity. He proposed a major government financed increase in rolling capacity – a 44-inch bloom mill, a 25 inch continuous billet mill, and all the ancillary equipment for rolling these new sizes of finished flat steel. The government eventually paid over 76% of the total cost of the new facilities.

Ottawa also paid the entire cost of a new blast furnace, the largest in Canada or the UK, on condition that the new furnace's production of pig iron output be subject to government discretion for five years after the war. Algoma held title to the furnace and received an operating subsidy. As a result Algoma became the largest pig iron producer in the country.

Algoma seized every opportunity thrown up by the 'steel crisis' during the war. By contrast, Dosco was lethargic in responding to government incentives, much to Howe's irritation. As a result, Dosco came out of the war with chronic cost and efficiency problems and would perpetually hover near collapse without further government aid. The script for the future Sysco's downward spiral was already written.

Public policy was also instrumental in the postwar heyday of the Canadian steel industry. The wartime expansion and reconversion to peacetime production were facilitated by a series of measures:

accelerated depreciation, government loans (some of them interest free) and remission of duties; and in some cases, capital assistance was extended by the government, assets of considerable value being turned over to the industry on very favourable terms. Algoma benefited particularly from the capital assistance plan. The companies therefore entered the postwar period with enlarged and improved plants acquired beyond what their balance sheets by themselves might have allowed. They also had enhanced financial positions as a result of the high operating levels during the war.

By 1955 the level of capacity acceptable to the industry and government had been achieved. The special depreciation programme was discontinued thereafter. In 1957, the first major revisions in the tariff system since 1907 took place with an industry much more confident in its ability to compete. The infant industry arguments and the steel industry's traditional demands for protectionism were set aside. It was accepted by all that a portion of specialty items with limited markets in Canada would be supplied by foreigners. This would act as something of a demand buffer for the industry. For the rest, Canada would have a self sufficient, modernized and competitive steel industry.

The qualifier in all of this was still the supply of iron ore. The 1960s was to see the major developments in Labrador iron ore mining carried out on a joint basis with US interests.

The Tipping Point Between Stelco and Dofasco

The story of the steel industry in most of the 20th century is the story of the Steel Company of Canada (Stelco), its emergence and leadership. The story of the past 25 years was largely the story of the displacement of Stelco by Dofasco as the innovation leader of the Canadian industry.

The tipping point between Dofasco and Stelco came in 1954. Technology and organization decisions at that point were the DNA of competitive challenges not fully realized until the 1990s.

Was there something in the drinking water in Canada in 1954?

Of the two transformative technologies in the global integrated steel industry – the Basic Oxygen Furnace (BOF) and the Continuous Casting Machine (CCM) – both were introduced in Canada in that year by small Canadian steel companies, years before either their Japanese or US competitors.

In the early postwar period, Dofasco was not an obvious candidate to become the most profitable steel company in North America by the New Millennium. Since its incorporation in 1910, The Steel Company of Canada (Stelco) was the undisputed leader of the Canadian steel industry in terms of production, product development and technical prowess. Stelco's position of dominance in Canada was roughly parallel to that of US Steel in the US industry. Dofasco was not even on the list of the six major Canadian steel producers in the report of the 1956 Royal Commission on Canada's Economic Prospects.

When Dofasco in 1954 became the first North American steel producer to introduce the Basic Oxygen Furnace (BOF), the company seemed an unlikely candidate to take the technological lead in the industry. It had no blast furnaces at the time and made its steel from scrap in a few small open hearths and electric furnaces. Indeed scrap prices and availability were the major motivators in the company's decision. Even after adding the new capacity, Dofasco would have just over 25% of total capacity of Stelco.

In the Korean War period there was a severe scrap shortage in North America coupled with very strong steel demand. Dofasco's management decided to reduce the company's dependence on scrap and to increase its production capacity by building a blast furnace. The challenge was to find the best way to increase steelmaking capacity. Dofasco's primary product was tin plate for the canning industry. Bessemer steel was not suitable for these products.

Mr. F.A. Loosely, Vice Chair of Dofasco was traveling in Europe and at a conference he heard about the BOF experiment in Austria from a supplier. He put Dofasco engineering onto the issue and eventually Dofasco secured a license and built a pilot plant.¹⁰

The initial installation comprised two BOF units (vessels). An additional unit was installed in 1956. A full year was spent running the technology in pilot mode, using the output to educate customers and using the process to train operators and staff in the new operations. And, it allowed Dofasco to engineer the first oxygen steel shop erected exclusively to accommodate the new process alone. The original two BOF shops commissioned were built in open hearth

10. The best documented account of Dofasco's introduction of the BOF is to be found Leonard Lynn's, *How Japan Innovates* (1982). It is that account on which the descriptive section of this paper largely relies.

structures that could serve dual use if necessary. Dofasco was able to design and implement a configurations with significant economic advantages over even the Austrians.

Writing just six months after the start-up, F.J. McMulkin, head of Dofasco's engineering department, could already characterize the BOF as a technology to challenge the older steelmaking techniques in producing a superior grade of low carbon steel. The benefits included: More even flow of steel to the hot mills with an appreciable saving of fuel for reheating, even though they were at this time still pouring to ingots. A steel which was much more uniform in its performance in cold rolling and annealing. A steel equally as good as that produced in the open hearth furnace and in some applications better.

Dofasco also pursued ancillary equipment developments. The distance between the new melt shop and the hot mill was 1.4 miles and a continuous flow of ingots would have fed into the already complex rail system. Dofasco designed and built a specially insulated and covered truck to transport the ingots. This not only assisted quality control because of the sensitivity of quality rolling to temperature variation in the ingots, but transport time was reduced to nine minutes. Delivery to the rolling mill was made into a continuous process and reheat fuel consumption was significantly reduced.

Moving quickly down the learning curve, Dofasco retired their existing open hearths completely within one year of the startup of the BOF shop. By 1959, the two original units had become inadequate and a new unit producing 135 tons of ingots per heat was installed.

By 1964, experience with the BOF combined with the addition of computerized control was allowing new approaches to temperature and therefore improved quality. This allowed them to eliminate the use of scrap completely by the 1960s.

The first pilot plant operations of the BOF at Dofasco were controlled by the time honoured method of gauging the end point by eye and controlling the slag condition and temperature by the usual visual and pyrometric means. However, they soon learned that these methods were just not fast enough or good enough for the new high speed steelmaking. As a result, Dofasco engineers specified that the new oxygen steelmaking shop would have a high –speed spectrometer laboratory facility as a production and quality aid.

A mathematical model, first developed at the sister BOF at Jones and Laughlin, resulted in the first successful effort to apply science to the control of final batch temperatures. After much refinement it was this algorithm that was incorporated into the subsequent computer control systems.

By the 1960s, there was a rising pace of innovation based on the experience of the first ten years of BOF operations, particularly around the improved control and refining processes for rapidly produced and higher quality steels. The effectiveness of this learning curve was directly attributable to the increased sharing of knowledge that the BOF innovation network had established.

Dofasco relied somewhat less on the European technology than the early Japanese adopters. The first converters and lances were made by a German firm but all other equipment was produced in North America. No Canadian engineers or operators were sent to Austria for training though an Austrian engineer was on hand for the actual start-up.

The Austrian inventors of the BOF had designed a process with two objectives in mind: To reduce the amount of scrap in the charge and to achieve a more thermally efficient process. Dofasco shared these objectives but came to understand that the BOF would have inherent quality advantages as well.

Stelco, the industry leader continued to invest in incremental improvements in Open Hearth technology, remaining well behind the curve until the later 1970s. With the significant qualifier of Stelco's slow adoption, the adoption rate of BOF technology in Canada was generally more rapid than that in the US, however by the end of the 1960s, adoption across the whole US industry was more complete than in Canada.

At Dofasco, technological innovation was matched by organizational innovation.

As discussed elsewhere in this Report the steel industry was an outlier in terms of adoption of Alfred Sloan's M-Form of multi-divisional enterprise as the normative model for the twentieth century corporation. Most steel companies including Stelco retained the Pre-Dupont/Sloan hierarchical model of organization. Dofasco however took a different path. It not only adopted the new BOF technology in the early 1950s, it also self-consciously adopted an organizational model which amounted to an early form of the matrix organization.

The Dofasco leadership were quite clear about not going the way of Stelco and other North American integrated steel corporations.

The Matrix form of organization began appearing in the 1950s in such companies as ITT, Dofasco and Matsushita. It overcame the fundamental problems of the M-form and other hierarchical forms of organization - the lack of horizontal lines of communication. Through task forces and project team managers, cross functional teams worked on developmental and specific problem solving issues.

Up to the mid-1950s Dofasco grew by expanding its facilities on the same site and on adjoining property. Personnel who witnessed changes since the 1930s suggest that the close physical proximity of management to the plant, together with the firm's relatively small size (1600 employees in 1937) fostered the open communication and informal administrative approaches that subsequently became integral parts of the corporation's 'culture.'

As Dofasco began to grow rapidly during the 1950s, Frank Sherman sought to preserve the firm's tradition of open communication, while developing the means to exert effective operational co-ordination over a wider range of productive processes. When he drew up Dofasco's first organizational chart in 1952, in response to the growing size of the executive team and the need to clarify functional relations, Sherman appended a memorandum that was intended to reassure staff accustomed to operating in an informal environment that open communication would continue.

The issuing of this chart does not mean that our long established policy of free interchange of ideas and opinions between men anywhere on the chart is to be altered in the slightest. The last thing we want is to become entangled in red tape. Much of Dofasco's success over the years has been due specifically to the lack of red tape. The purpose [of devising the diagram] is to clarify general relationships between the positions shown . . . and indicate the general spheres of activity for each one. The location, vertically or horizontally of a position has no significance

Frank Sherman, May 1952

In looking at the divergence of different fortunes of Stelco and Dofasco it is not a question of one company learning and the other not. They both learned but they learned different things in different networks of knowledge.

Dofasco (1952)

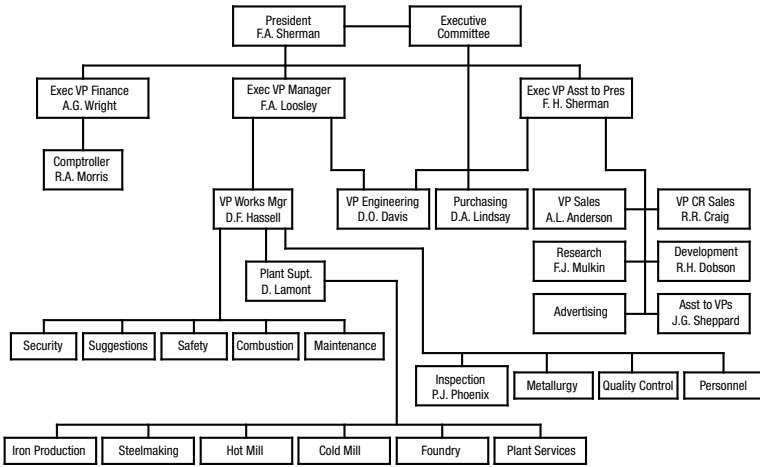

Source: Boyce & Ville (2002)

Dofasco embarked on a different path, not a straight line from 1954 onwards. As an organization, it more easily adapted to the Japanese continuous process revolution, including active dialogue with the Japanese innovators, presenters at conferences, technical publications, etc. Out of all of this Dofasco evolved a more inclusive learning culture. It also embarked on the new technology path of the BOF with a different industry and customer orientation.

Embeddedness in networks is often seen as a critical advantage for industrial innovation, however in Stelco's case it may have been a case of being over-embedded.

The impact of industrial standards in steel cannot be overstated. Dofasco was outside the SAE standards, therefore they were in an open field to introduce the breakthrough technology. But, it also forced the company into a different posture regarding knowledge transfer. They spent the next ten years interacting directly with customers, then with standards bodies *through* the customers, because that is how SAE standards are developed.

It is not a matter that Dofasco couldn't do anything wrong and Stelco never did anything right. Unlike the Japanese early BOF adopters, who then rapidly moved to Continuous Caster, it was twenty years before Dofasco introduced the CC machine. Stelco by contrast piloted

a Caster even before adopting the BOF. The Japanese ability to combine all the elements of postwar steel technology breakthroughs together was linked to building a high number of Greenfield sites. Dofasco remained to this day at its original site. Stelco basically bet the future of the company on its new Nanticoke, Lake Erie Works in the early 1980s. LEW was significantly successful but in turn left a fundamental technological imbalance in the steel production flows with its existing Hilton Works where a majority of the finishing capacity was located.

Stelco meanwhile was mired in its traditional hierarchical engineering-based system of knowledge. It only learned what its engineers learned. This epistemology was institutionalized in Stelco Engineering, the technical leaders in the industry; and, onto the shopfloor of the collective agreement through the management rights clause and the skill hierarchies of CWS.

The elimination of Stelco Engineering, the largest downsizing of engineering talent in Canadian business history after Ontario Hydro, signaled the end of an age. No more would steel innovation be dependent on indigenous, deep engineering talent within the corporation. The smaller but more nimble Dofasco simply caught the wave and accelerated past Stelco with less than 10% of the complement of Stelco's engineers. Dofasco learned differently and applied what they learned differently than their competitors.

The combined outcome of all these developments were two:

First, Dofasco became a learning steel company and the most profitable integrated steel maker in North America. Second, Stelco, lagged behind, then tried to discontinuously institute its version of the Kimitsu experiment at Lake Erie Works at Nanticoke, but wound up on the pathway to CCAA because it was on a fundamentally different learning curve.

The Japanese steel industry was transformed; the Canadian industry flowed the benefits and the losses to individual steel companies.

Historical Bibliography:

- Bailey, M. and Boyce, G. (1989) "The Manufacturing and Marketing of Steel in Canada: Dofasco Inc., 1912-1970", *Business and Economic History*, 2nd, V. 18 228-237
- Bartlett, J. (1885) *The Manufacture, Consumption and Production of Iron, Steel Coal in the Dominion of Canada*, Montreal
- Birnbaum, Cohen, Harris and Warrian (2009) Ontario Manufacturing, Supply Chains and Knowledge Networks: A Report to the Toronto Regional Research Alliance (TRRA), Toronto: TRRA October 2009
- Boyce, G. (1990) "Continuity and Transition in Corporate Capability: Incentives, Management and Innovation at Dofasco Inc.", *Business and Economic History*, 2nd, V. 19 223-233
- Donald, W. (1915) *The Canadian Iron and Steel Industry: A Study in the Economic History of a Protected Industry*, Boston
- Eldon, D. (1952) "American Influence in the Canadian Iron and Steel Industry", Harvard Ph.D. Thesis
- Elver, R. (1969) "Economic Character and Change in the Canadian Steel Industry since 1945", Ottawa: Mineral Information Bulletin MR94, Mineral Resources Branch, Department of Energy Mines and Resources
- Firestone, O.J. (1949) *Encouragement to Industrial Expansion in Canada: Operation of Special Depreciation Provisions, Apr. 10, 1944-31 March 1949*, Ottawa
- Hogan, W. (1971) *Economic History of the Iron and Steel Industry in the United States*, Lexington, MA: Heath
- Howe, C.D. (1944) *The Industrial Front*, Ottawa
- Ker, S. Tze (1972) "Technological Change in the Canadian Iron and Steel Mills Industry 1946-69", PhD Thesis University of Manitoba
- Kilbourn, W. (1960) *The Elements Combined*, Toronto: Clarke Irwin
- Lynn, L. (1982) *How Japan Innovates*, Boulder: Westview Press
- McDowall, D. (1988) *Steel at the Sault*, Toronto: University of Toronto Press
- McMulkin, F.J. (1955) "Oxygen Steelmaking in Canada", Proceedings of the Open Hearth Conference.
- McMulkin, F.J. (1955) "Oxygen Steelmaking: How Canadian Plant Uses New Process", *Iron Age*, March 31, 1955: 75-8
- McMulkin, F.J. (1964) "Ten Years of Oxygen Steelmaking at Dofasco", *The Canadian Mining and Mineral Bulletin*, October 1964.
- Merritt, W. (1890-1) "Notes on the Possibilities of Iron and Steel Production in Ontario", *Transactions of the Canadian Institute*
- Morgan, L. I. (1956) *The Canadian Primary Iron and Steel Industry*, Ottawa: Queen's Printer
- Prior, L. (1956) "Sault Ste. Marie and the Algoma Steel Corporation Ltd", M.A. Thesis, University of Toronto
- Porritt, E. (1907) "Iron and Steel Bounties in Canada" *Political Science Quarterly*, 22:2 (June 1907)
- Singer, J. (1969) *Trade Liberalization and the Canadian Steel Industry*, Toronto
- Speer, C. "History of the Algoma Steel Corporation", PAC MG 31 B3

Appendix 2 – Methodology

Details on Steel Multiplier Estimates

Steel companies usually define the industry as including the steel producers and the distributors and processors in the Steel Service Centres. Statscan has a code ‘NAICS 3311 Primary Steel’ which includes most but not all of the steel producing companies. Steel Service Centres who are crucial suppliers for auto and construction are partly in NAICS 3312 and partly under Metal Fabricators NAICS 4162 but the latter includes non-Steel construction material suppliers such as cement and bricks.

The industrial codes for input/output models are based on three digit codes, so for instance, NAICS Primary Metals includes Steel but also a dozen others such as aluminum, which is not a factor in Ontario but is important in Quebec and BC.

In the Informetrica study, the technical coefficients for important factors such as labour inputs and material inputs for steel are well within the ranges for the technical coefficients for manufacturing industries. Therefore, the general estimates by Informetrica for manufacturing industries as a whole are reliable for the steel industry.

The Canadian Steel Producers Association (CSPA) website claims that the steel industry directly employed 30,000 Canadians in 2008. The number will be lower for 2009.

In terms of government sources, a useful starting point is NAICS codes 331 (primary metal manufacturing) and 332 (fabricated metal product manufacturing). In Ontario, “primary metal manufacturing” employs 25,600 people and “fabricated metal product manufacturing” employs 63,000 people.

These codes encompass more than any reasonable, strict definition of the steel industry. It is not appropriate to start from the premise that steel directly employs 88,600 people in Ontario alone and then apply a multiplier to that figure. More importantly it would be more problematic to use those broad codes nationally, given the scale of the aluminum industry in Quebec and BC.

If we use code 331 (the great majority of which is steelmaking in Ontario), but not code 332 (which includes a wide range of metal manufacturing), then direct employment is 25,600. With the application of a multiplier, a reasonable estimate of the steel industry is arrived at.

References

- Adams, R. (1952), “The Development of the United Steelworkers of America”, MA Thesis, Kingston: Queen’s University
- Aylen, J. (2001) “Where did Generation V strip mills come from?”, *Steel Times*, July/August 2001: 225-234
- Bailey, M. and Boyce, G. (1989) “The Manufacturing and Marketing of Steel in Canada: Dofasco Inc., 1912-1970”, *Business and Economic History*, 2nd, V. 18 228-237
- Bartlett, J. (1885) *The Manufacture, Consumption and Production of Iron, Steel Coal in the Dominion of Canada*, Montreal
- Birnbaum, Cohen, Harris and Warrian (2009) Ontario Manufacturing, Supply Chains and Knowledge Networks: A Report to the Toronto Regional Research Alliance (TRRA), Toronto: TRRA October 2009
- Boyce, G. (1990) “Continuity and Transition in Corporate Capability: Incentives, Management and Innovation at Dofasco Inc.”, *Business and Economic History*, 2nd, V. 19 223-233
- Donald, W. (1915) *The Canadian Iron and Steel Industry: A Study in the Economic History of a Protected Industry*, Boston
- Eldon, D. (1952) “American Influence in the Canadian Iron and Steel Industry”, Harvard PhD. Thesis
- Elver, R. (1969) “Economic Character and Change in the Canadian Steel Industry since 1945”, Ottawa: Mineral Information Bulletin MR94, Mineral Resources Branch, Department of Energy Mines and Resources
- Estey, W. (1974) *Steel Profits Inquiry Report*, Ottawa
- Firestone, O.J. (1949) *Encouragement to Industrial Expansion in Canada: Operation of Special Depreciation Provisions, Apr. 10, 1944-31 March 1949*, Ottawa
- Gertler, M. (2004) *Manufacturing Culture*, Oxford: Oxford University Press
- Heron, C. (1991) *Working in Steel: The early Years in Canada*, Toronto: McLelland and Stewart
- Hogan, W. (1971) *Economic History of the Iron and Steel Industry in the United States*, Lexington, MA: Heath
- Holweg, M. and Pil, F. (2004) *The Second Century*, Cambridge, MA: MIT Press
- Howe, C.D. (1944) *The Industrial Front*, Ottawa
- Hutchison, J. (1993) “Algoma Steel Inc.: employee buyout case history”, Unpublished article completed for Queen’s University School of Business, Kingston, Ontario.
- Ker, S. Tze (1972) “Technological Change in the Canadian Iron and Steel Mills Industry 1946-69”, PhD Thesis University of Manitoba
- Kilbourn, W. (1960) *The Elements Combined*, Toronto: Clarke Irwin
- Lynn, L. (1982) *How Japan Innovates*, Boulder: Westview Press
- McCartney, J.C. (1996) “Algoma Steel Inc: a successful restructuring” in J.S. Zeigel (ed) *Case studies in recent Canadian insolvency reorganizations*, Canada: Carswell.

- McCourt, R. (1995) *Worker ownership as a labour tactic? The Algoma Steel experience*. A paper submitted to the School of Industrial Relations in partial fulfillment of the requirements for the Master of Industrial Relations degree, Queen's University, Kingston, Ontario.
- McDowall, D. (1988) *Steel at the Sault*, Toronto: University of Toronto Press
- McMulkin, F.J. (1955) "Oxygen Steelmaking in Canada", Proceedings of the Open Hearth Conference.
- McMulkin, F.J. (1955) "Oxygen Steelmaking: How Canadian Plant Uses New Process", *Iron Age*, March 31, 1955: 75-8
- McMulkin, F.J. (1964) "Ten Years of Oxygen Steelmaking at Dofasco", *The Canadian Mining and Mineral Bulletin*, October 1964.
- Merritt, W. (1890-1) "Notes on the Possibilities of Iron and Steel Production in Ontario", *Transactions of the Canadian Institute*
- Misa, T. J. (1995), *A Nation of Steel*, Baltimore: Johns Hopkins University Press
- Morgan, L. I. (1956) *The Canadian Primary Iron and Steel Industry*, Ottawa: Queen's Printer
- Orr, A. (1978) *Report of the Consultative Task Force on the Canadian Iron and Steel Industry*, Ottawa: ITC
- Prior, L. (1956) "Sault Ste. Marie and the Algoma Steel Corporation Ltd", M.A. Thesis, University of Toronto
- Porritt, E. (1907) "Iron and Steel Bounties in Canada" *Political Science Quarterly*, 22:2 (June 1907)
- Rhys, G. (1998) "Steel and the Automotive Sector: Future Prospects", *Steel Times*, Sep98, Vol. 226 Issue 9, p326
- Singer, J. (1969) *Trade Liberalization and the Canadian Steel Industry*, Toronto
- Speer, C. "History of the Algoma Steel Corporation", PAC MG 31 B3
- Stieber, J. (1961) "Work Rules and Practices in Mass Production Industries", *IRRA Proceedings*, 1961: 399-412
- Stieber, J. (1959) *The Steel Industry Wage Structure*, Cambridge: Harvard University Press
- Stone, K. (1974) "The Origins of Job Structures in the Steel Industry", *Review of Radical Political Economists*, 6 (Summer 1974)61-97; reprinted in Edwards et al *Labor Market Segmentation*
- Tiffany, P. (1982) "Industrial Policy and the Decline of the American Steel Industry", *Journal of Contemporary Business*, 11:1, 58
- Treado, C. (2008) "Sustaining Pittsburgh's Steel Technology Cluster", University of Pittsburgh, September 2008
- Wansbrough, V. (1950) "Implications of Canadian Iron Ore Production", *CJEPCC*, 16 (1950) 239
- Warrian, P. and Mulhern, C. (2003) "Learning in Steel: Agents and Deficits" in D. Wolfe(ed.) *Clusters Old and New: The Transition to a Knowledge Economy in Canada's Regions*, Montreal & Kingston: McGill-Queens University Press, 2003.

- Warrian, P. and Mulhern, C. (2005) “Knowledge and Innovation in the Interface between the Steel and Auto Industries: The Dofasco Case”, *Regional Studies*, Vol. 39.2, pp. 161–170, April 2005
- Watson, J. (1945) “Hamilton and Its Environs”, *Canadian Geographical Journal*, May 1945
- Wells, P. (2001) “Platforms: engineering panacea, marketing disaster?”, *Journal of Materials Processing Technology*, 115 (2001) 166-170
- Wells, P. (2002) “Cars and Wide Strip Steel: Welded Together By History”, Centre for Automotive Industry Research, Cardiff Business School, Mimeo (March 2002)
- Wells, P. (2004) “Creating Sustainable Business Models: The Case of the Automotive Industry”, *IIMB Management Review*, Vol. 16, 4 (Dec 2004), 15
- Wixted, B. (2008) Cluster Rents: Strategic Organizations and/or System Resources?”, DRUID: Copenhagen, CBS, Denmark, June 17 - 20, 2008
- Wolfe, D. and Lucas, M. (2005) *Global Networks and Local Linkages*, McGill-Queen's University Press
- Yonekura, S. (1994) *The Japanese Iron and Steel Industry, 1850-1990*, New York: St. Martin's Press
- Yonekura, S., (1995), “Technological innovation in the steel industry: Recognizing potential in innovations”, in Minawi, R., Kim, K.S., Makino, F., Seo, J.H. (eds.), *Acquiring, Adapting and Developing Technologies*, New York, St. Martin's Press.
- Yonekura, S. (1997) “The Innovation Process in the Japanese Steel Industry” in Goto, A. and Odagiri, H. (eds.) *Innovation in Japan*, Oxford: Clarendon Press